

RECORD POWER
ESTABLISHED 1909®

Original Instruction Manual

WG200 Wet Stone Sharpening System

Version 3.1
September 2016



To register this product please visit
www.recordpower.info

It is important to register your product as soon as possible in order to receive efficient after sales support and be entitled to the full **5 year guarantee**. Your statutory rights are not affected.
Please see back cover for contact details.



Always wear safety glasses when using woodworking equipment.



Always read the instructions provided before using woodworking equipment.

Important

For your safety read instructions carefully before assembling or using this product.

Save this manual for future reference.

Contents

- 1 Explanation of Symbols
- 2 General Health and Safety Guidance
- 3 Additional Health and Safety Guidance for Wet Stone Sharpeners
- 4 Record Power Guarantee
- 5 Specifications
- 6 Contents of the Package
- 7 Getting to Know Your Machine
- 8 Assembly
- 9 Operation
- 10 Optional Jigs for the WG200 Wet Stone Sharpener
 - 10.1 **WG250/A** Gouge Jig
 - 10.2 **WG250/B** Short Tool Jig
 - 10.3 **WG250/C** Straight Edge Jig
 - 10.4 **WG250/D** Plane Camber Jig
 - 10.5 **WG250/E** Scissor Jig
 - 10.6 **WG250/F** Side Wheel Sharpening Jig
 - 10.7 **WG250/G** Short Knife Jig
 - 10.8 **WG250/H** Long Knife Jig
 - 10.9 **WG250/I** Tool Rest Jig
 - 10.10 **WG250/J** Axe Jig
 - 10.11 **WG250/O** Support Arm Extension Kit
 - 10.12 **WG250/N** Profiled Leather Honing Wheel
- 11 Maintenance
- 12 Troubleshooting
- 13 Electrical Connection and Wiring Diagram
- 14 Parts Lists and Diagrams
 - EU Certificate of Conformity

1. Explanation of Symbols

The symbols and their meanings shown below may be used throughout this manual. Please ensure that you take the appropriate action wherever the warnings are used.

Mandatory Instructions



Read and fully understand the instruction manual before attempting to use the machine.



Indicates an instruction that requires particular attention



Wear protective eyewear



Use respiratory protective equipment



Use hearing protection



Use suitable protective footwear



Use protective work gloves

Warnings



Indicates a risk of severe personal injury or damage to the machine



Indicates a risk of severe personal injury from electrical shock



Risk of personal injury from lifting of heavy items



Indicates a risk of severe personal injury from airborne objects



Risk of fire

2. General Health and Safety Guidance

Ensure that you carefully read and fully understand the instructions in this manual before assembly, installation and use of this product. Keep these instructions in a safe place for future reference.

WARNING: for your own safety, do not attempt to operate this machine until it is completely assembled and installed according to these instructions.

WARNING: When using any machine, basic safety precautions should always be followed to reduce the risk of fire, electric shock and personal injury.

Safe Operation

1. Use Personal Protective Equipment (PPE)

- The operation of any machine can result in foreign objects being thrown into your eyes, which can result in severe eye damage. Protective eyewear or other suitable eye protection or face shield should be used at all times. Everyday spectacles only have impact resistant lenses. They are not protective eyewear and do not give additional lateral protection.
- Use respiratory protective equipment (dust mask etc.) if the machining operation creates dust. Exposure to high levels of dust created by machining hardwoods, softwoods and man made composite boards can result in serious health problems. Some imported hardwoods give off highly irritating dust, which can cause a burning sensation. The use of respiratory protective equipment should not be seen as an alternative to controlling the risk of exposure at source by using adequate dust extraction equipment.
- The use of ear plugs or ear defenders is recommended when the machine is in use, particularly if the noise level exceeds 85 dB.
- Wear suitable protective gloves when handling cutting tools or blades. Gloves should NOT be worn when using the machine as they can be caught in moving parts of the machine.
- Non-slip safety footwear is recommended when using the machine and handling large work pieces.

2. Dress appropriately

- Do not wear loose clothing, neckties or jewellery; they can be caught in moving parts of the machine.
- Roll up long sleeves above the elbow.
- Wear protective hair covering to contain long hair.

3. Safety warnings

- Find and read any warning labels on the machine.
- It is important that any labels bearing health and safety warnings are not removed, defaced or covered. Replacement labels can be obtained by contacting our Customer Service Department.

4. Familiarise yourself with the machine

- If you are not thoroughly familiar with the operation of this machine, obtain advice from your supervisor, instructor, or other qualified person or contact your retailer for information on training courses. Do not use this machine until adequate training has been undertaken.

5. Take care when moving or positioning the machine

- Some machines can be very heavy. Ensure the floor of the area in which the machine is to be used is capable of supporting the machine.
- The machine and its various components can be heavy. Always adopt a safe lifting technique and seek assistance when lifting heavy components. In some cases it may be necessary to use mechanical handling equipment to position the machine within the work area.
- Some machines have optional wheel kits available to allow them to be manoeuvred around the workshop as required. Care should be taken to install these according to the instructions provided.
- Due to the nature of the design of some machines the centre of gravity will be high making them unstable when moved. Extreme care should be taken when moving any machine.
- If transportation of the machine is required then all precautions relating to the installation and handling of the machine apply. In addition, ensure that

any vehicles or manual handling equipment used for transportation are of adequate specification.

6. The machine should be level and stable at all times

- When using a leg stand or cabinet base that is designed to be fitted to the machine, always ensure that it is securely fastened to the machine using the fixings provided.
- If the machine is suitable to be used on a workbench, ensure that the workbench is well constructed and capable of withstanding the weight of the machine. The machine should always be securely fastened to the workbench with appropriate fixings.
- Where possible, floor standing machines should always be secured to the floor with fixings appropriate to the structure of the floor.
- The floor surface should be sound and level. All of the feet of the machine should make contact with the floor surface. If they do not, either re-locate the machine to a more suitable position or use packing shims between the feet and the floor surface to ensure the machine is stable.

7. Remove adjusting keys and wrenches

- Ensure that all adjusting wrenches and keys are removed before switching the machine 'ON'. There is a risk of severe personal injury or damage to the machine from airborne objects.

8. Before switching the machine 'ON'

- Clear the machine table of all objects (tools, scrap pieces etc.)
- Make sure there is no debris between the work piece and the table / work support.
- Ensure that the work piece is not pressed against, or touching the saw blade or cutting tool.
- Check all clamps, work holding devices and fences to ensure that they are secure and cannot move during machining operations.
- Plan the way that you will hold and feed the work piece for the entire machining operation.

9. Whilst machining

- Before starting work, watch the machine while it runs. If it makes an unfamiliar noise or vibrates excessively, switch the machine 'OFF' immediately and disconnect it from the power supply. Do not restart until finding and correcting the source of the problem.

10. Keep the work area clear

- Working clearances can be thought of as the distances between machines and obstacles that allow safe operation of every machine without limitation. Consider existing and anticipated machine needs, size of material to be processed through each machine and space for auxiliary stands and/or work tables. Also consider the relative position of each machine to one another for efficient material handling. Be sure to allow yourself sufficient room to safely operate your machines in any foreseeable operation.
- Cluttered work areas and benches create the risk of accidents. Keep benches clear and tidy away tools that are not in use.
- Ensure that the floor area is kept clean and clear of any dust and debris that may create trip or slip hazards.

11. Consider the work area environment

- Do not expose the machine to rain or damp conditions.
- Keep the work area well lit and ensure that there is artificial lighting available when there is insufficient natural light to effectively light the work area. Lighting should be bright enough to eliminate shadow and prevent eye strain.
- Do not use the machine in explosive environments eg. in the presence of flammable liquids, gases or dust.
- The presence of high levels of dust created by machining wood can present a risk of fire or explosion. Always use dust extraction equipment to minimise the risk.

12. Keep other persons away (and pets)

- The machine is designed to be used by one person only.
- Do not let persons, especially children, touch the machine or extension

2. General Health and Safety Guidance

cable (if used) and keep visitors away from the work area.

- Never leave the machine running unattended. Turn the power supply off and do not leave the machine unattended until it comes to a complete stop.
- If the work area is to be left unattended, all machinery should be switched 'OFF' and isolated from the mains power supply.

13. Store machines safely when not in use

- When not in use, machines should be stored in a dry place, out of reach of children. Do not allow persons unfamiliar with these instructions or with the machine to operate it.

14. Do not overreach

- Choose a working position that allows your body to remain balanced and feed the work piece in to the machine without overreaching.
- Keep proper footing and balance at all times.

15. Electrical supply

- Electrical circuits should be dedicated to each machine or large enough to handle combined motor amp loads. Power outlets should be located near each machine so that power or extension cables are not obstructing high-traffic areas. Observe local electrical guidelines for proper installation of new lighting, power outlets, or circuits.
- The machine must be connected to an earthed power supply.
- The power supply must be equipped with a circuit breaker that provides short circuit, overload and earth leakage protection.
- The voltage of the machine must correspond to the voltage of the mains power supply.
- The mains plug fitted to the machine should always match the power outlet. Do not modify the plug in any way. If a replacement plug is required it should be fitted by a competent person and of the correct type and rating for the machine.
- If you are unsure about any electrical connections always consult a qualified electrician.

16. Avoid unintentional starting of the machine

- Most machines are fitted with a no-volt release (NVR) switch to prevent unintentional starting. If in doubt always ensure the machine switch is in the 'OFF' position before connecting it to the power supply. This means the machine will not automatically start up after a power cut or switching on of the power supply, unless you first reset the start switch.

17. Outdoor use

- Your machine should not be used outdoors.

18. Extension cables

- Whenever possible, the use of extension cables is not recommended. If the use of an extension cable is unavoidable, then it should have a minimum core cross section of 2.5mm² and limited to a maximum length of 3 metres.
- Extension cables should be routed away from the direct working area to prevent a trip hazard.

19. Guard against electric shock

- Avoid body contact with earthed or grounded surfaces such as pipes and radiators. There is an increased risk of electric shock if your body is earthed or grounded.

20. Always work within the machine's intended capacities

- Operator safety and machine performance are seriously adversely affected if attempts to make the machine perform beyond its limits are made.

21. Do not abuse the power cable

- Never pull the power cable to disconnect it from the power socket. Always use the plug.
- Keep the power cable away from heat, oil and sharp edges.
- Do not use the power cable for carrying or moving the machine.

22. Secure the work piece

- Ensure that the work piece is securely held before starting to machine it.
- When working within 300 mm of the machining area, always use a push stick to feed the work piece in to the blade or cutting tool. The push stick

should have a minimum length of 400 mm. If the push stick becomes damaged, replace it immediately.

- Use extra supports (roller support stands etc.) for any work pieces large enough to tip when not held down to the table top.
- Do not use another person as a substitute for a table extension, or as additional support for a work piece that is longer or wider than the basic table, or to help feed, support, or pull the work piece.
- Do not attempt to machine more than one work piece at a time.
- When feeding the work piece towards the blade or cutting tool never position your hands in direct line of the cutting path. Avoid awkward operations and hand positions where a sudden slip could cause your hand or fingers to move into the machining area.

23. Stay alert

- Safety is a combination of operator common sense and alertness at all times when the machine is being used.
- Use all machines with extreme care and do not use the machine when you are tired or under the influence of drugs, alcohol or medication.

24. Use the correct tool for the job

- Do not use the machine for any purpose other than which it was designed.
- When selecting replacement cutting tools and blades, always ensure that they are designed to cut the material that you intend to use them for. If in any doubt seek further advice from the manufacturer.

25. Connect dust extraction equipment

- Always use dust extraction equipment. The dust extractor should be of suitable size and capacity for the machine that it is connected to and have a filtration level appropriate to the type of waste being collected. Refer to the relevant section of the manual for details of the specific dust extraction requirements for this machine.
- The dust extractor should be switched 'ON' before starting the machine that it is connected to. The dust extractor should be left running for 30 seconds after the last machining operation is complete in order to clear any residual waste from the machine.

26. Ensure that the machine is correctly guarded

- Never use the machine if any of the standard safety guards and equipment are removed or damaged.
- Some machines incorporate safety interlocks to prevent the machine from being used without the guards in place. Never attempt to bypass or modify the interlocks to allow the machine to be used without the guards in place.

27. Maintain your machine with care

- This manual gives clear instructions on installation, set up and operation of the machine and also details any routine and preventative maintenance that should be performed periodically by the user.
- Remember always to switch off and unplug the machine from the power supply before carrying out any setting up or maintenance operations.
- Follow any instructions for the maintenance of accessories and consumables.
- Do not use compressed air to clean the machine. Always use a brush to dislodge dust in places that are awkward to reach and a dust extractor to collect the waste.
- Inspect electric cables periodically and, if damaged, have them replaced by an authorised service facility or qualified electrician.
- Inspect extension cables (if used) periodically and replace if damaged.

28. Keep cutting tools sharp and clean

- Correctly maintained cutting tools are easier to control and less likely to bind.
- Cutting tools and blades can become hot during use. Take extreme care when handling them and always allow them to cool before changing, adjusting or sharpening them.

29. Disconnect the machine from the power supply

- When not in use, before servicing, changing blades etc. always disconnect

2. General Health and Safety Guidance

the machine from the power supply.

30. Check for damaged parts

- Before each use of the machine, it should be carefully checked to determine that it will operate properly and perform its intended function.
- Check for alignment of moving parts, binding of moving parts, breakage of parts and any other conditions that may affect the operation of the machine.
- A guard or other part that is damaged should be properly repaired or replaced by a qualified person unless otherwise indicated in this instruction manual.
- Do not use the machine if the switch does not turn the machine 'ON' and 'OFF'.
- Have defective switches replaced by a qualified person.

31. Warning!

- The use of any accessory or attachment, other than those recommended in this instruction manual, or recommended by our Company may present a risk of personal injury or damage to the machine and invalidation of the warranty.

32. Have your machine repaired by a qualified person

- This machine complies with the relevant safety rules and standards appropriate to its type when used in accordance with these instructions and with all of the standard safety guards and equipment in place. Only qualified persons using original spare parts should carry out repairs. Failure to do this may result in considerable danger to the user and invalidation of warranty.

33. Caution! Motor may become hot during use

- It is normal for motors on some machines to become hot to the touch during use. Avoid touching the motor directly when in use.

3. Additional Health and Safety Guidance for Wet Stone Sharpeners

Safe Operation

- The wet stone sharpener should be level and stable at all times.
- The machine should be placed on a suitable workbench. Depending on the sharpening application, access will be required to both sides of the grinder, so it is not practical to fix the machine to the work bench.
- When positioning the machine on the bench, ensure that there are no objects between the base of the machine and the bench surface and that all four feet of the machine make contact with the bench.

2. Familiarise yourself with the machine

- Although the wet stone sharpener runs at relatively low speed, there are still risks present that can lead to accidents. Most accidents with this type of machine involve trapping of fingers or hands between the exposed sharpening stone or honing wheel and the body of the machine, or loose clothing being drawn in to the moving parts. In addition there is the risk of injury from the sharp edges of the tool.
- The risk of breakage is inherent in every abrasive wheel. The level of risk is lower with slow speed grinders. Always handle grinding wheels with extreme care. They are brittle and the slightest impact can cause fractures within the stone.
- This machine is designed for the sharpening and honing of tools, knives, chisels, axes etc made of metal. It should not be used for any other purpose.
- The machine and particularly the sharpening stone should be protected from frost. If the water retained within the stone freezes it can cause the stone to crack. If the machine is not to be used for long period, empty the water trough, remove the sharpening stone and store it in a dry place at temperatures above 5°C.

3. Before switching the machine 'ON'

- Select the correct jig or fixture for holding the tool to be sharpened. The manual details all of the jigs available for the machine and the correct method of using them.
- Take the time to ensure that the jig is set correctly to achieve the correct sharpening angle for the application and that the fixings are secure.
- Check that there is sufficient water in the trough to keep the stone wet whilst sharpening. If the stone is dry, it will soak up approximately 0.5 litres of water in the first few minutes of running.
- Check the condition of the stone. If damaged or cracked replace the stone immediately.
- Rotate the stone by hand to ensure that it can move freely without interference from other components.

- Check that the speed control is set to correspond with the diameter of the sharpening stone mounted on the machine.

4. Whilst sharpening / honing:

- When the machine is first switched 'ON', allow it to run for up to a minute before applying the work piece.
- Regularly check the water level and top up as necessary. It may take several minutes before the sharpening stone is fully saturated and for the water level to remain constant.
- Certain sharpening applications may need to be carried out on the side of the stone. It is safe to use the side of the stone for sharpening providing that the 'side jig' is used for control of the work piece.
- When honing, always have the honing wheel running away from the edge of the tool. Never attempt to hone towards the edge as the tool will dig in to the honing wheel and may be thrown from the machine and the honing wheel damaged.

5. Maintenance

- Regularly check the condition of the surface of the sharpening stone. The compound of the stone is quite soft and grooves can wear in to the face of the stone quite easily. Dress the stone regularly as described in the manual. Do not attempt to apply the dressing tool to the honing wheel.
 - If steel is exposed to water for prolonged periods, rust will form. If rust forms on any of the exposed components of the machine, they should be cleaned and lubricated to prevent further damaged.
 - The dust from abrasive wheels can be an irritant and a hazard to your health. As the sharpening stone runs at slow speed and in water, the risk from air borne dust whilst sharpening is minimal. However, waste dust will collect in the water trough and there is a risk of exposure as the trough dries out. Always use the machine in a well ventilated area and use additional respiratory protective equipment when cleaning the machine. When the machine is dry clean it with a vacuum cleaner to remove waste material.
6. This machine falls under the scope of the 'Health and safety at Work etc. Act 1974', and the 'Provision and Use of Work Equipment Regulations 1998'. We recommend that you study and follow these regulations.

Further guidance can be found in the 'Safety in the use of abrasive wheels – publication HSG17' published by Health and safety Executive and available from their website www.hse.gov.uk.

4. Record Power Guarantee

“**Products**” means the Products sold by Record Power subject to these terms and conditions;

“**Record Power**” is Record Power Limited, whose company registration number is 4804158 and registered office address is Centenary House, 11 Midland Way, Barlborough Links, Chesterfield, Derbyshire S43 4XA and sells through a network of Authorised Dealers;

“**Authorised Distributor**” is the nominated importer for your region who will generally sell through a network of Authorised Dealers. Details of Authorised Distributors for specific countries can be found in the Product manual or at www.recordpower.info;

“**Authorised Dealer**” is a retailer or business authorised to sell Record Power Products to end users.

1 Guarantee

- 1.1 Record Power guarantees that for a period of 5 years from the date of purchase the components of qualifying Products (see clauses 1.2.1 to 1.2.9) will be free from defects caused by faulty construction or manufacture.
- 1.2 During this period Record Power, its Authorised Distributor or Authorised Dealer will repair or replace free of charge any parts which are proved to be faulty in accordance with paragraphs 1.1 above provided that:
 - 1.2.1 you follow the claims procedure set out in clause 2 below;
 - 1.2.2 Record Power, our Authorised Distributor or Authorised Dealer are given a reasonable opportunity after receiving notice of the claim to examine the Product;
 - 1.2.3 if asked to do so by Record Power, its Authorised Distributor or Authorised Dealer, you return the Product, at your own cost, to Record Power's premises or other approved premises such as those of the Authorised Distributor or supplying Authorised Dealer, for the examination to take place;
 - 1.2.4 the fault in question is not caused by industrial use, accidental damage, fair wear and tear, wilful damage, neglect, incorrect electrical connection, abnormal working conditions, failure to follow our instructions, misuse, or alteration or repair of the Product without our approval;
 - 1.2.5 the Product has been used in a domestic environment only;
 - 1.2.6 the fault does not relate to consumable Products such as blades, bearings, drive belts or other wearing parts which can reasonably be expected to wear at different rates depending on usage (for full details contact Record Power or your local Authorised Distributor);
 - 1.2.7 the Product has not been used for hire purposes, by you or by a previous owner;
 - 1.2.8 the Product has been purchased by you as the guarantee is not transferable from a private sale.
 - 1.2.9 where the Product has been purchased from a retailer, the 5 year guarantee is transferable and begins on the date of the first purchase of the Product and in the event of a claim under this guarantee proof of the original purchase date will be required to validate the warranty period.

2 Claims Procedure

- 2.1 In the first instance please contact the Authorised Dealer who supplied the Product to you. In our experience many initial problems with machines that are thought to be due to faulty parts are actually solved by correct setting up or adjustment of the machines. A good Authorised Dealer should be able to resolve the majority of these issues much more quickly than processing a claim under the guarantee.
- 2.2 Any damage to the Product resulting in a potential claim under the guarantee must be reported to the Authorised Dealer from which it was purchased within 48 hours of receipt.
- 2.3 If the Authorised Dealer who supplied the Product to you has been unable to satisfy your query, any claim made under this Guarantee should be made directly to Record Power or its Authorised Distributor (for details of the Authorised Distributor in your country please see your Product manual or check www.recordpower.info for details). The claim itself should be made in a letter setting out the date and place of purchase, and giving a brief explanation of the problem which has led to the claim. This letter should then be sent with proof of the purchase date (preferably a receipt) to Record Power or its Authorised Distributor. If you include a phone number or email address this will help to speed up your claim.
- 2.4 Please note that it is essential that the letter of claim reaches Record Power or its Authorised Distributor on the last day of this Guarantee at the latest. Late claims will not be considered.

3 Limitation of Liability

- 3.1 We only supply Products for domestic and private use. You agree not to use the Product for any commercial, business or re-sale purposes and we have no liability to you for any loss of profit, loss of business, business interruption or loss of business opportunity.
- 3.2 This Guarantee does not confer any rights other than those expressly set out above and does not cover any claims for consequential loss or damage. This Guarantee is offered as an extra benefit and does not affect your statutory rights as a consumer.

4 Notice

This Guarantee applies to all Products purchased from an Authorised Dealer of Record Power within the United Kingdom of Great Britain and Northern Ireland. Terms of Guarantee may vary in other countries – please check with the Authorised Distributor in your country (details of the Authorised Distributor for your country can be found in the manual or at www.recordpower.info).

5. Specifications

Voltage: 230 V

Frequency: 50 Hz

Motor input P1: 0.16 kW

Motor output P2: 0.12 kW

Motor speed: 3800 rpm

Full load current: 0.7 A

Stone size: 200 x 40 mm

Stone bore: 12 mm

Honing wheel size: 180 x 30 mm

Honing wheel bore: 12 mm

Speeds: 120 - 250 rpm / 1.25 - 2.6 M/second

Weight: 8.5 kg

6. Contents of the Package

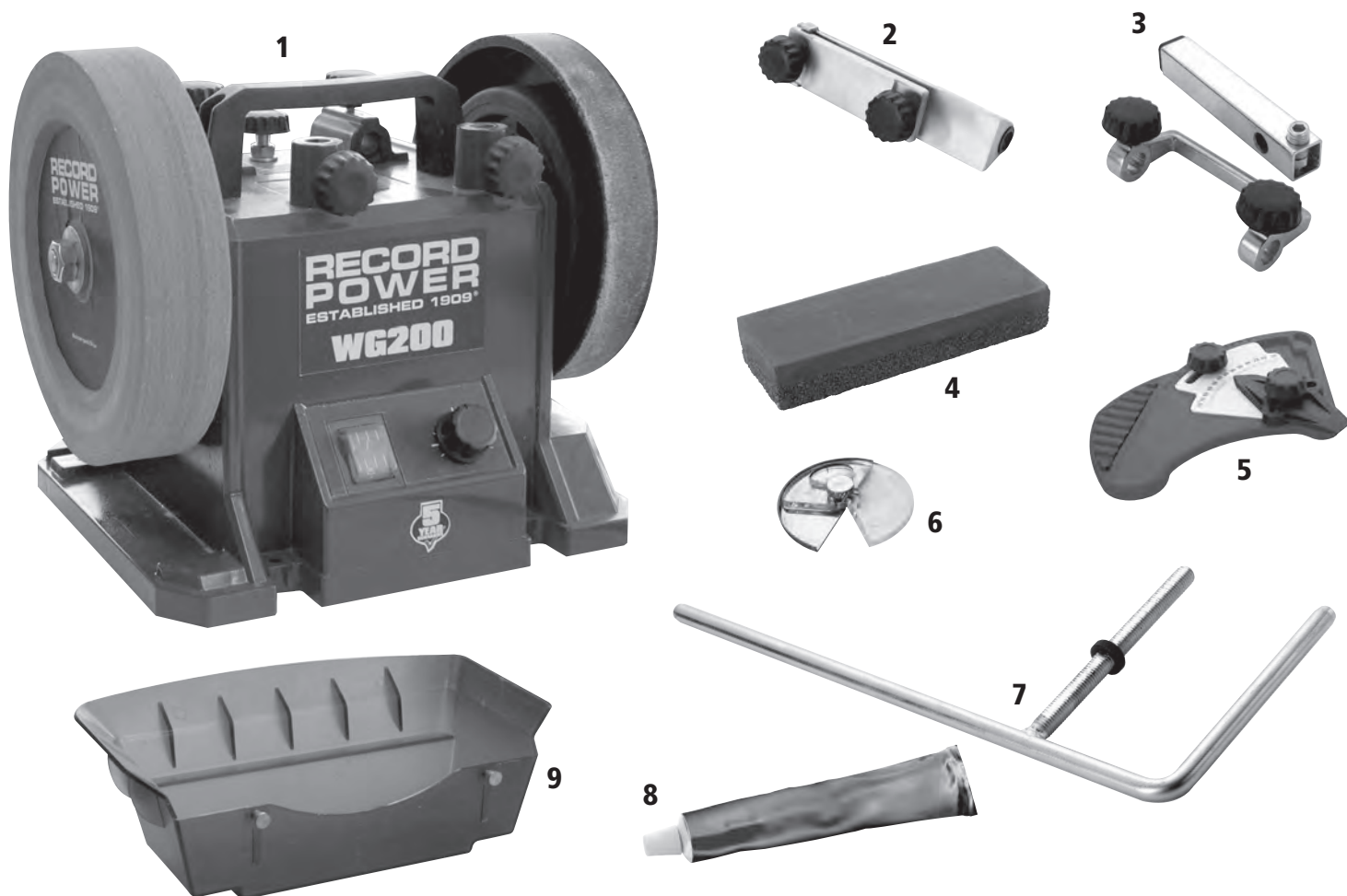

- 1 **WG200** Wet Stone Sharpener
- 2 **WG250/C** Straight Edge Jig
- 3 **WG250/K** Diamond Trueing Tool
- 4 **WG250/R** Stone Grader
- 5 **WG250/T** Angle Setting Gauge
- 6 **WG250/U** Angle Finder
- 7 **WG250/P** Support Arm
- 8 **WG250/S** Honing Compound
- 9 Water trough

7. Getting to Know Your Machine

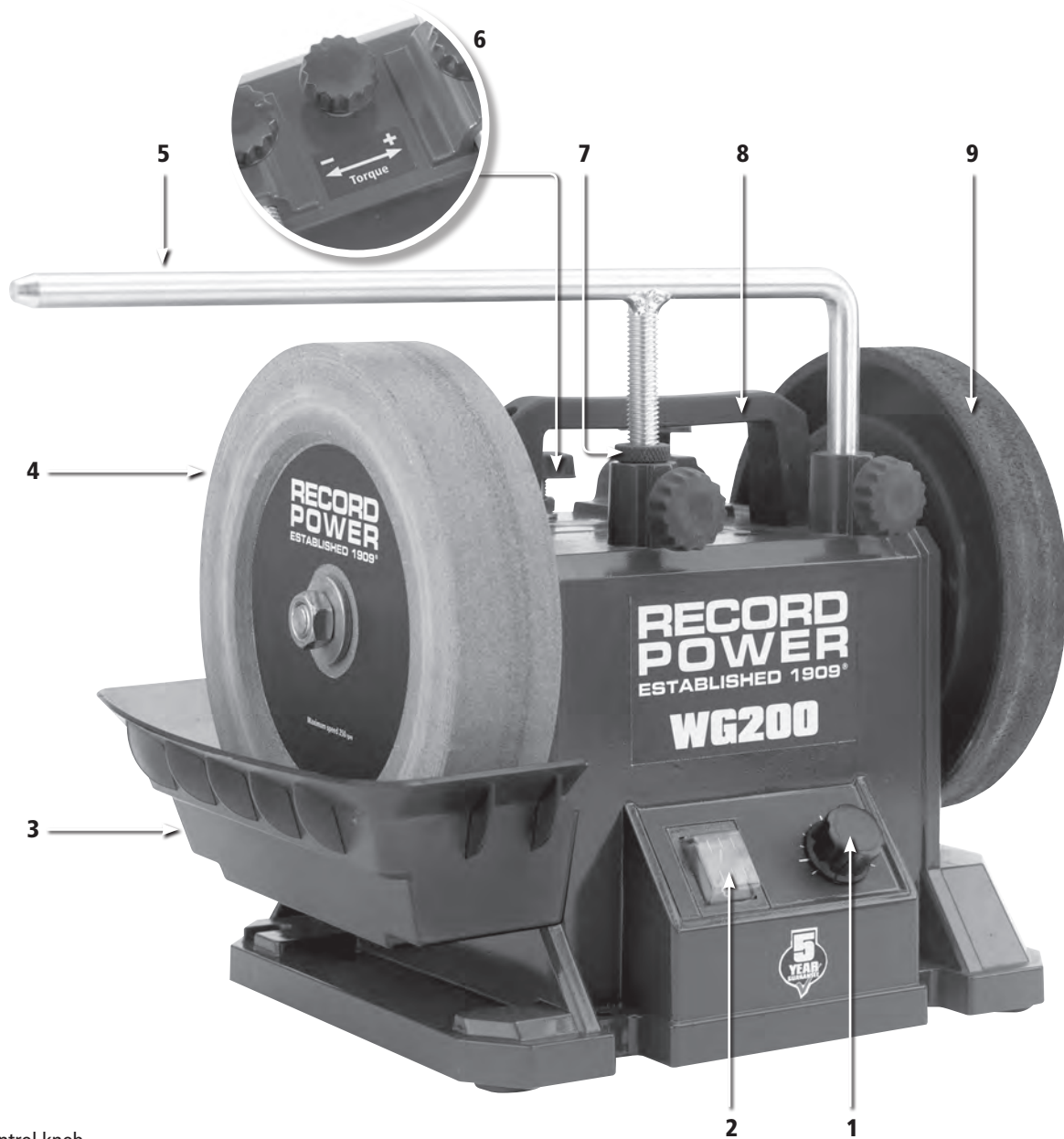

- 1 Speed control knob
- 2 On / off switch
- 3 Water trough
- 4 200 mm (8") sharpening stone
- 5 Support arm
- 6 Torque control knob
- 7 Support arm micro adjustment collar
- 8 Carrying handle
- 9 Leather honing wheel

8. Assembly

The WG200 features 2 sets of brackets for installing the support arm - The upper brackets as shown in **Fig 8.1** and the side brackets as shown in **Fig 8.2**.

When using the **WG250/C** Straight Edge Jig and the **WG250/K** Diamond Trueing tool, the upper brackets must be used.

Install the support arm to the upper brackets as shown in **Fig 8.1**.

Install the water trough to the machine as shown in **Fig 8.3** (the stone has been removed only to allow the holes to be seen) by hooking the brass brackets shown in **Fig 8.4** into the lower set of holes on the side of the machine. The upper holes are to be used when the stone has reduced in size through wear and it is too small to come into contact with the water in the trough.

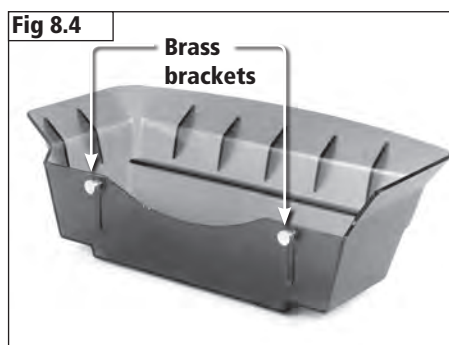
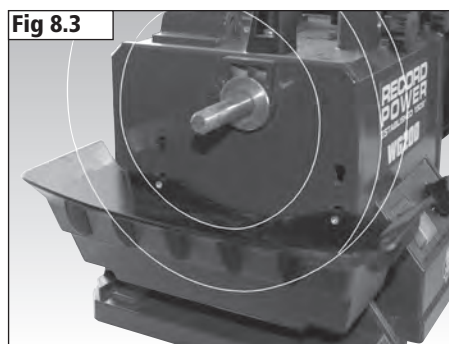
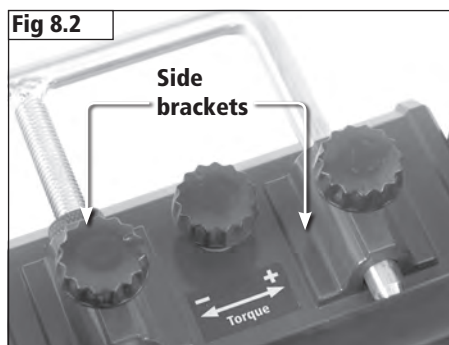
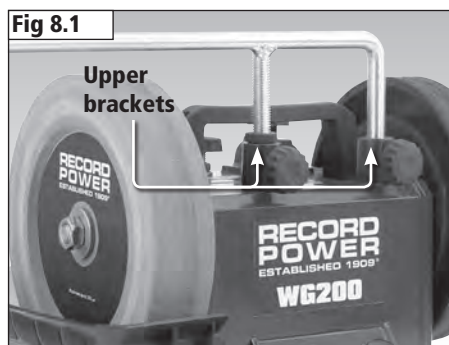

8. Assembly

Assembly of the Optional WG250/N Profiled Leather Honing Wheel

The profiled honing wheel is supplied with a shaft extension and 2 washers as shown in **Fig 8.5**.

Remove the knob that holds the honing wheel to the machine as shown in **Fig 8.6**.

Fit the shaft extension as shown in **Fig 8.7**.

Fit the profiled honing wheel to the shaft as shown in **Fig 8.8** with a washer on either side and re-fit the knob.

Apply mineral oil and honing paste before use.

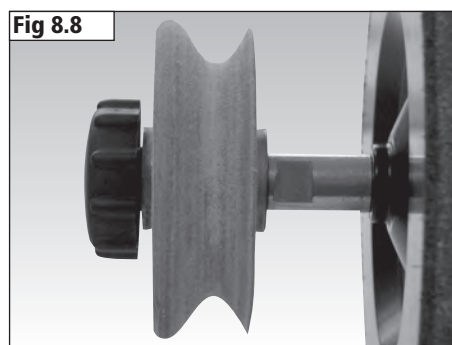
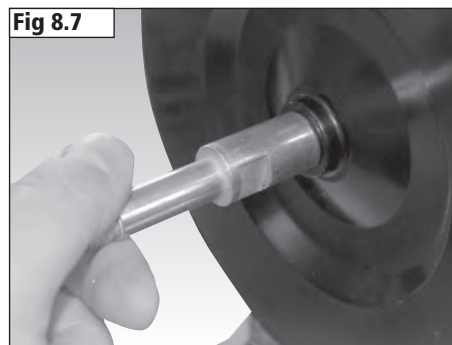
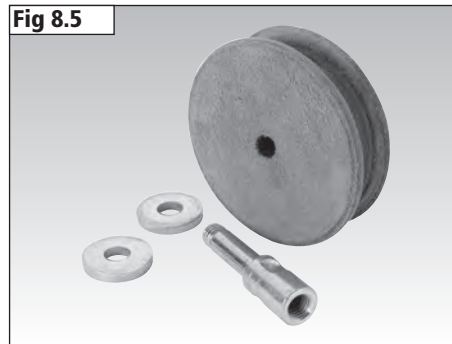

9. Operation



All operations described in this manual must be carried out with sufficient water in the trough to ensure the stone remains wet during use. This is to ensure no damage to the sharpening stone or items being sharpened occurs.

Fill the water trough with cold or room temperature water to the level of the lip as shown in **Fig 9.1**.

With the speed control knob set at the lowest speed, turn the machine on using the switch on the front, **Fig 9.2**.



The speed of rotation can be increased to compensate for the wear of the stone. Increasing the speed as the stone becomes smaller will retain the sharpening speed. The speed can also be increased to sharpen more quickly.

As the wheel turns it will absorb water. Slowly add water to the trough as the stone absorbs it until the water level remains constant.



Remove the water trough when the machine is not in use. If the trough is left on, the bottom of the wheel will sit in water and become unbalanced.

Trueing the Stone

The stone should be trued before use so it is parallel with the support arm as shown in **Fig 9.3**. This will ensure accurate results.

If the stone is new it may already appear parallel to the support bar but it is recommended to carry out the truing procedure regardless as any inaccuracies that are not visible to the naked eye will be corrected.

Trueing the stone also ensures that the stone is concentric to its shaft.

Ensure the tip of the tool is secured in place as shown in **Fig 9.4** by using a 6 mm hex wrench to tighten the securing screw.

Mount the support arm in the upper position.

Place the guide bar on the support arm with the trueing bar beneath it as shown in **Fig 9.5**. The guide bar must be facing towards the front of the machine and the tip of the tool facing towards the rear of the machine as shown.

Fig 9.1

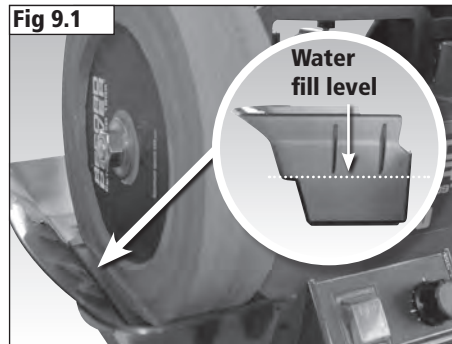

Fig 9.2

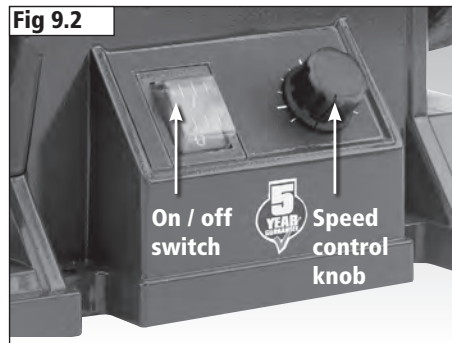

Fig 9.3

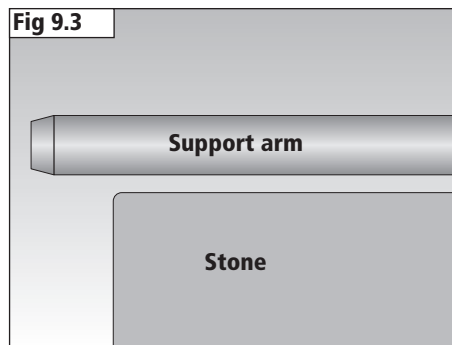

Fig 9.4

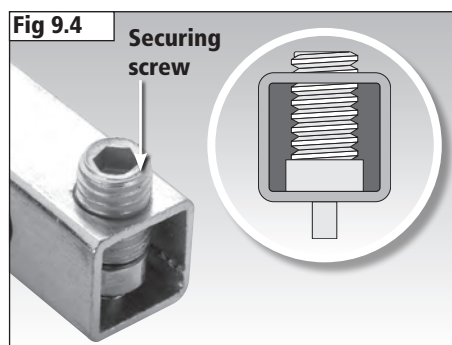
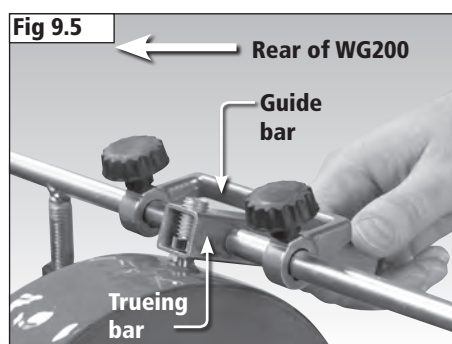

Fig 9.5



9. Operation

To position the support arm, loosen the upper bracket locking knobs, **Fig 9.6**, move the arm into position and re-tighten the knobs. The micro adjustment collar can be used if necessary for fine adjustment.

For best results position the guide bar so that when the trueing bar is in contact with it the tip of the tool is parallel to the stone's surface as shown in **Fig 9.7**.

Position the tip of the tool to lightly touch the stone. Lift the tip from the stone and turn the machine on. Raise the trueing bar to touch the guide bar as shown in **Fig 9.7** and slowly move the tip from left to right across the full width of the stone until the tip is in continuous contact, **Fig 9.8**.

If the stone is being trued after a period of use, then position the tip to touch the highest point of the stone as shown in **Fig 9.9**.

If the tip is intermittently in contact with the stone after carrying out the above procedure, lower the tip slightly and repeat until continuous contact is achieved.

The stone must also be trued to be concentric to its shaft. To achieve this, true the stone until the tip of the tool touches across the stone's full circumference as well as its full width.

As the trueing tool is used the tip will wear. To ensure even wear across its surface it can be rotated by loosening the securing screw as shown in **Fig 9.4** with a 6 mm hex wrench, repositioning the tip and re-tightening the screw.

Dressing the Stone

The stone's surface must be dressed for use after it has been trued.

Use the **WG250/R** Stone Grader to apply either a coarse or fine surface to the stone as shown in **Fig 9.10**, by applying it for approximately 30 seconds with reasonable force to the stone as it rotates.

The darker side of the stone gives a coarse finish for quickly grinding material away from the tool, ideal for reshaping tool profiles.

The lighter side gives a fine finish, suitable for achieving a razor sharp edge to existing tool profiles.

The stone grader can also be used to rejuvenate the stone's surface if it becomes glazed from use.

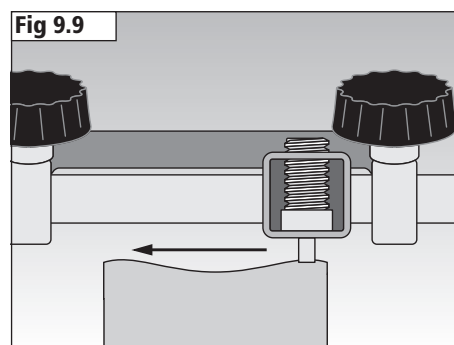
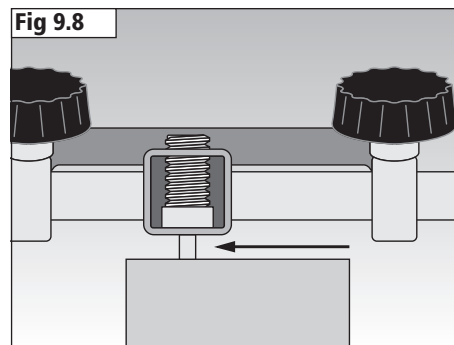
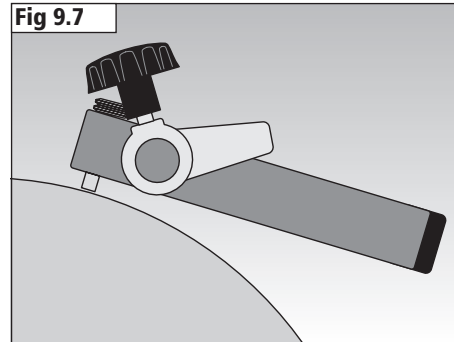
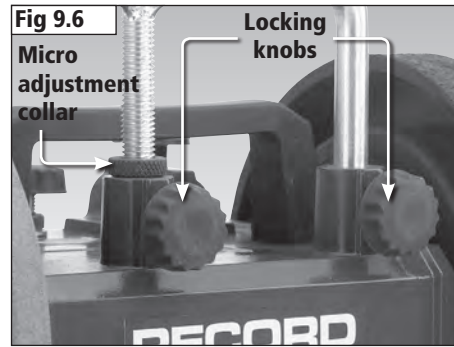

9. Operation

Finding the Existing Angle of the Tool to be Sharpened

Use the angle finder as shown in **Fig 9.11** to find the angle of the edge to be sharpened. The angle shown is 25°.

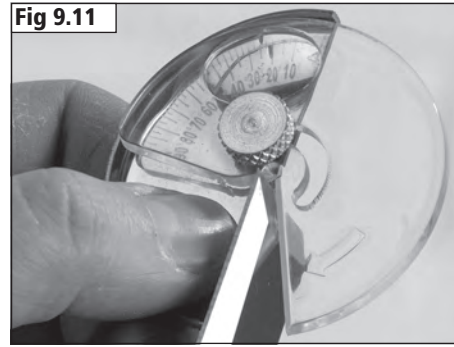

Setting the Angle Setting Gauge

Loosen the diameter and pointer knobs, **Fig 9.12**. Slide the white scale until the indicators align with the correct diameter of the stone. When new the stone is 200 mm (8") in diameter. The indicator on the left points to metric and the right points to imperial measurements. Tighten the diameter knob then adjust the pointer to align with the desired angle to sharpen the tool at.

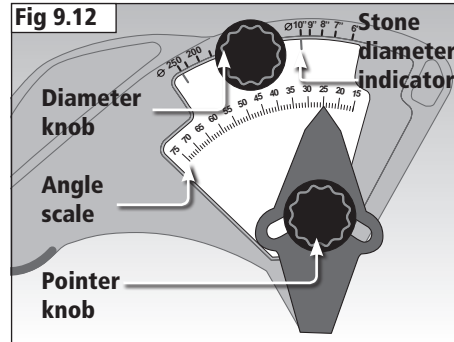

Sharpening a Plane Blade using the Straight Edge Jig



The straight edge jig can be used to sharpen a variety of different tools. The plane blade here is shown as an example.

Loosen the two locking knobs, **Fig 9.13**, and place the plane blade into the jig with the surface to be sharpened pointing downwards as shown in **Fig 9.14**.

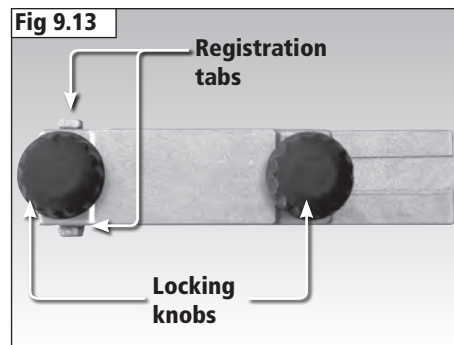

Align the side of the blade with the registration tabs on the jig as shown in **Fig 9.13**. This will ensure the edge to be sharpened is at 90° to the stone. Re-tighten the locking knobs.

Mount the support arm in the upper position and place the jig on the support arm, **Fig 9.14**.

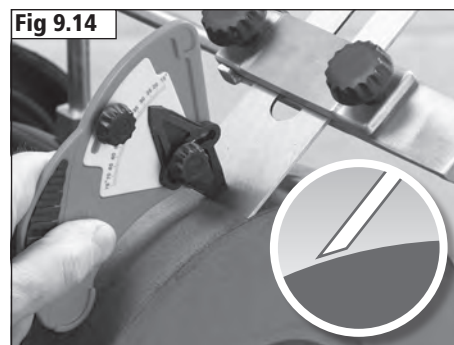

Place the angle setting gauge on the stone as shown in **Fig 9.14** then adjust the position of the support arm until the rear face of the blade is aligned with the flat area at the bottom of the pointer as shown.

Turn the machine on and slowly move the tool surface across the stone as shown in **Fig 9.15** until the required sharpness is achieved.



9. Operation

Adjusting the Torque

The torque of the friction drive can be increased if required to cope with greater application of pressure during sharpening, see **Fig 9.16**.

Honing the Tool

After sharpening the tool on the stone it can be honed if required to increase its sharpness.

Before the first use of the honing wheel mineral oil should be applied to the leather surface, **Fig 9.17**. The mineral oil is available as part of the **WG250/X** Maintenance Kit. If the maintenance kit is not available then an alternative mineral oil can be used. The oil will stop the honing paste from soaking deep into the leather.



Do not apply lubricating oil to the honing wheel.

Carefully apply honing paste to the wheel using a clean rag or sponge as shown in **Fig 9.18** until even coverage is achieved.

Place the support arm in the side position as shown in **Fig 9.19**.

Mark the edge to be honed with a black marker pen as shown in **Fig 9.20**.

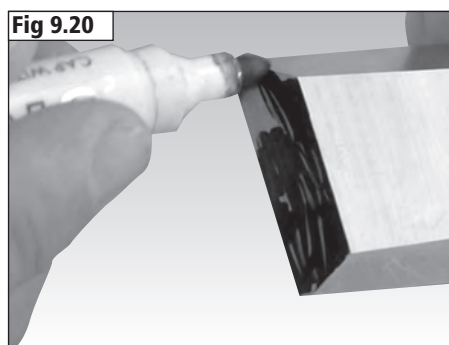
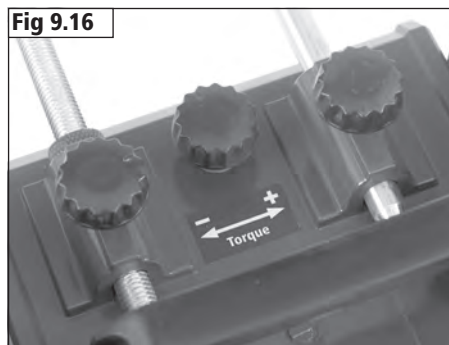

9. Operation

Place the straight edge jig onto the support arm and position it so that the tool edge is parallel with the honing wheel as shown in **Fig 9.21**. Turn the wheel by hand as shown in **Fig 9.22**. If the black ink is removed evenly across the tool's edge then the angle is correct.

Turn the machine on and apply the tool to the honing wheel until the required finish is achieved.



Always hone any tool with the wheel moving away from it. If the wheel is moving towards the tool the leather may be damaged.

In the Event of a Blockage or if the Machine Stalls

If the machine stalls due to the work piece or other foreign body becoming trapped, switch the machine off immediately by pressing the red button on the switch marked 'O'.

Locate and rectify the source of the blockage. If the work piece has become trapped between the sharpening stone and the jig, the surface of the stone may become damaged. It may be necessary to dress or true the stone before attempting to use the stone again.

Check that the sharpening stone can be turned freely by hand before attempting to re-start the machine. Re-start the machine by pressing the green button on the switch marked 'I'.

In the Event of a Power Failure

In the event of a power failure, first switch the machine off by pressing the red button marked 'O' on the switch.

Locate and rectify the source of the failure. If the fault is within the power circuit of the workshop, there may be an underlying cause (circuit overload etc.) that should be investigated by a qualified electrician before attempting to restore the power source.

Once the power is restored, re-start the machine by pressing the button marked 'I' on the switch.

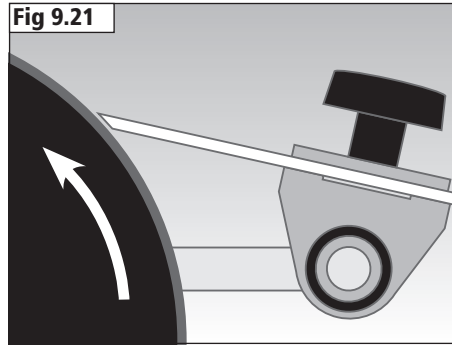

10. Optional Jigs for the **WG200** Wet Stone Sharpener

To complement the **WG200** Wet stone Sharpener Record Power offers an extensive range of jigs to allow the sharpening of a wide range of tools.

For further information on the Record Power jig range or to purchase please contact your local retailer or visit the Record Power website.



WG250/A Gouge Jig



WG250/B Short Tool Jig



WG250/C Straight Edge Jig

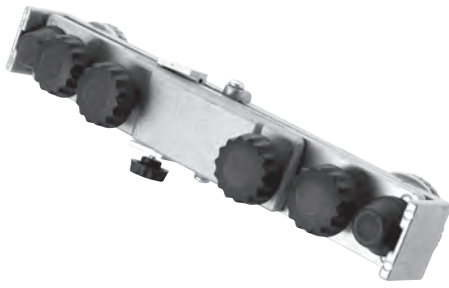

WG250/D Plane Camber Jig



WG250/E Scissor Jig



WG250/F Side Wheel Sharpening Jig



WG250/G Short Knife Jig



WG250/H Long Knife Jig

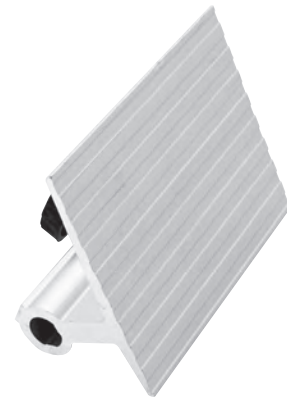

WG250/I Tool Rest Jig



WG250/J Axe Jig



WG250/O Support Arm Extension Kit



WG250/N Profiled Leather Honing Wheel

10.1 WG250/A Gouge Jig

Use to sharpen:

- Bowl gouges
- Spindle gouges
- V-tools

The gouge jig attaches to the support arm of the wet stone sharpener.

- A** Knob screw
- B** Tool holder
- C** Shaft
- D** Support arm mount
- E** Elbow joint

Using the Gouge Jig

Mount the tool in the tool holder with the required length of blade protruding to allow enough clearance between the jig and stone when in use. The protrusion varies depending on the tool being sharpened and a good rule of thumb is at least 50 mm (2") is sufficient for many tools. See **Fig 10.1.1**.

Adjust the angle of the shaft relative to the tool holder using the hex head socket screw located in the elbow joint. For shorter side bevels, such as those found on bowl gouges, lock the shaft in the uppermost position and for longer bevels, as on spindle gouges, lock the shaft in lower positions. See **Fig 10.1.2**.



Please note this should be done before setting the position of the tool to the correct bevel angle as any adjustments of the shaft after this will change the bevel angle that will be applied to the stone.

Place the support arm in the side position.

Secure the support arm mount to the support arm and align it centrally to the cutting face of the sharpening wheel. See **Fig 10.1.3**.

With the tool secured in the tool holder, place the shaft in the recess of the support arm mount as shown in **Fig 10.1.4**.

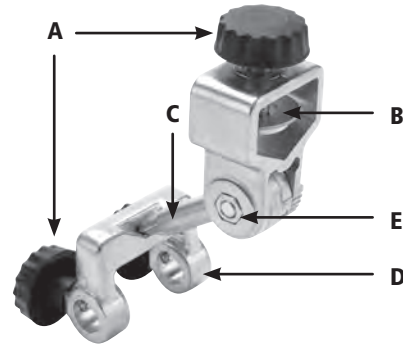

Fig 10.1.1

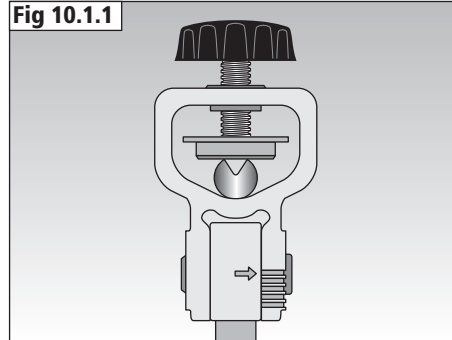

Fig 10.1.2

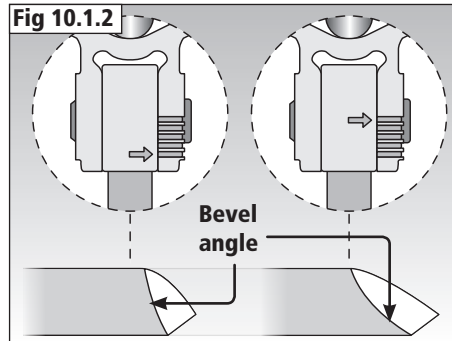

Fig 10.1.3

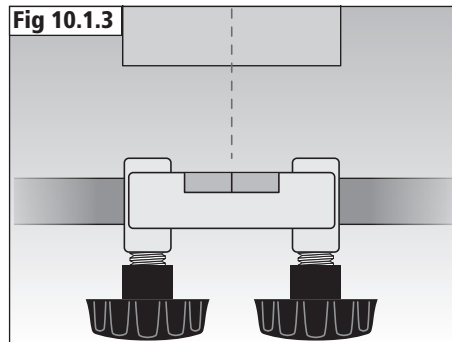
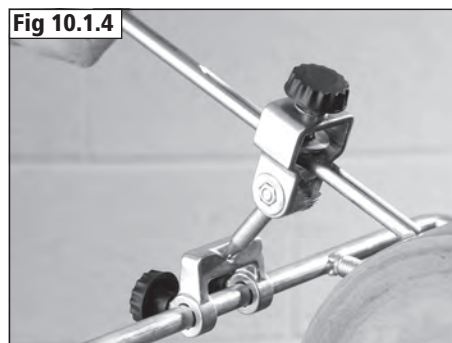
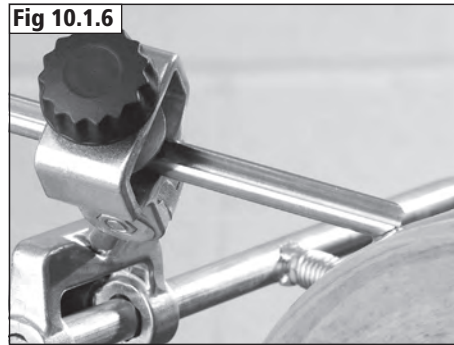
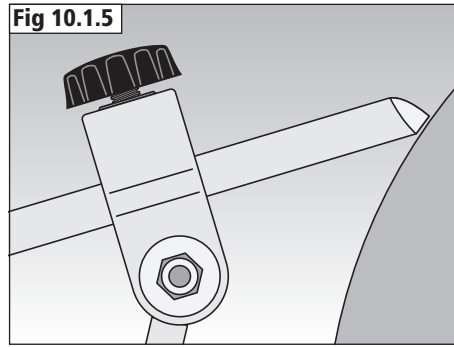

Fig 10.1.4



10.1 WG250/A Gouge Jig

Carefully apply the tool to the wheel, see **Fig 10.1.5**, ensuring contact is kept whilst pivoting the shaft to sharpen all the way round the edge. See **Fig 10.1.6**.



10.2. WG250/B Short Tool Jig

Use to sharpen:

- Small carving tools
- Small gouges
- V-tools

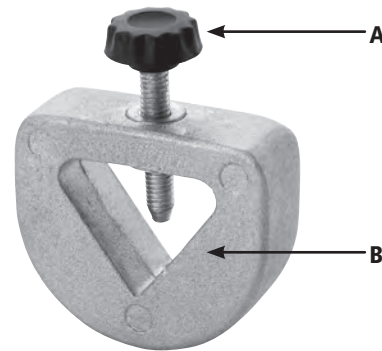

The Short Tool Jig rests on the support arm of the wet stone sharpener.

A Knob screw

B Tool holder

Using the Short Tool Jig

Fit the support arm in the side position.

Slide the tool into the tool holder **B** and lock in place with knob screw **A**.

A combination of the support arm position and the position of the tool in the jig can be used to set the correct sharpening angle.

Hold the jig against the support arm as shown in **Fig 10.2.1**.

For most carving tools and other thin edge tools it is advisable to grind away from the edge of the tool for increased control.

Apply the tool to the stone as shown in **Fig 10.2.1** and rotate the jig to sharpen the tool's edge.



10.3. WG250/C Straight Edge Jig

Use to sharpen:

- Plane irons
- Bevel edge chisels

The straight edge jig slides onto the support arm of the wet stone sharpener.

A Registration bar

B Clamp

C Lock knobs

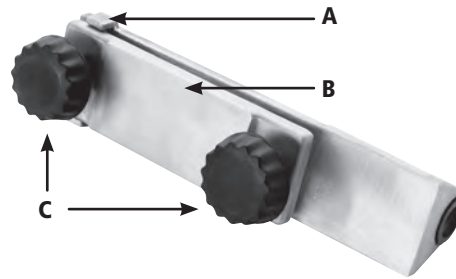

Using the Straight Edge Jig

Mount the support arm in the upper position.

Place the tool into the jig and ensure it is resting against the registration bar as shown in **Fig 10.3.1**.

Tighten both lock knobs equally to ensure the tool remains parallel to the jig.

Slide the straight edge jig on to the support arm and move the tool slowly from side to side across the sharpening stone as shown in **Fig 10.3.2**.

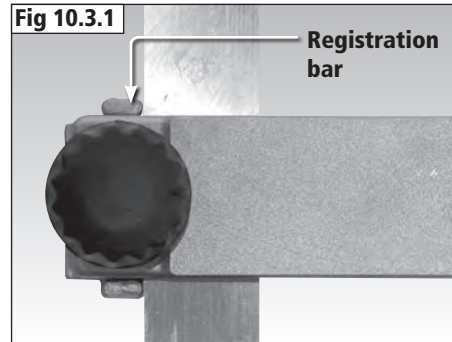

10.4. WG250/D Plane Camber Jig

Use to sharpen camber plane blades up to 76 mm (3" wide).

The plane camber jig slides on the support arm of the wet stone sharpener.

A Camber lock knob

B Camber setting screw and lock

C Fence

D Blade lock knob

E Rocker pad

Using the Plane Camber Jig to Sharpen a Camber

Mount the support arm in upper position.

Position the plane blade in the centre of the jig as shown in **Fig 10.4.1**. Use the fence to ensure the blade is at 90° to the jig, **Fig 10.4.2**, then lock the blade in place using the blade lock knobs.

Ensure the camber lock knobs are released to allow the camber plate to move as shown in **Fig 10.4.3**.

To set the desired camber, position the camber setting screw as required and secure in place with the lock as shown in **Fig 10.4.3**. The depth of camber will increase when the screw is set in the lower positions.

Both camber setting screws and locks must be set equally to achieve a symmetrical camber to the blade.

Position the blade at the required angle to the stone and pass across the stone from left to right, holding down the left hand rocker pad as shown in **Fig 10.4.4**.

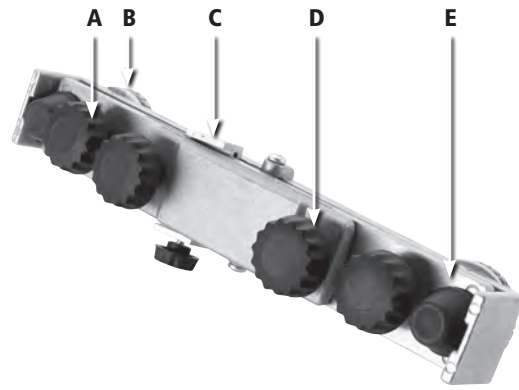

Fig 10.4.1

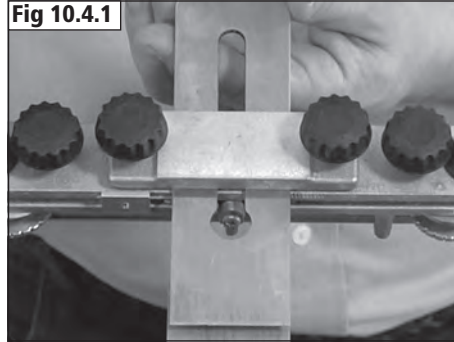

Fig 10.4.2

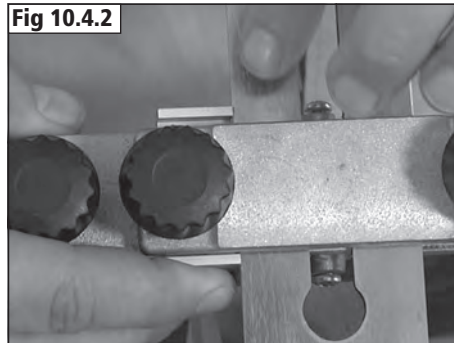

Fig 10.4.3

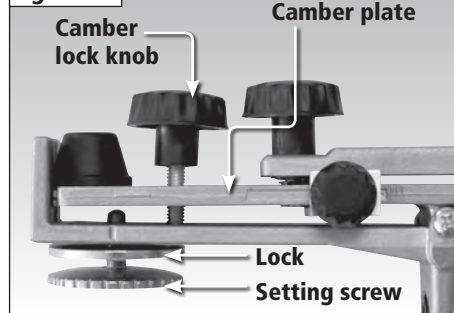
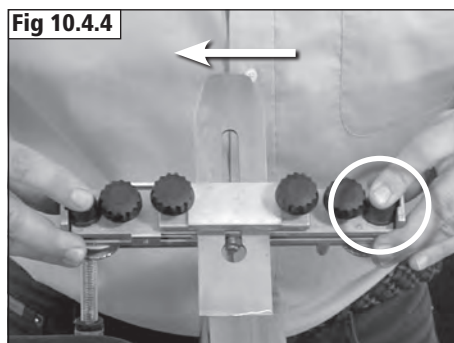

Fig 10.4.4



10.4. WG250/D Plane Camber Jig

Pass the blade back across the stone from right to left whilst holding down the right hand rocker pad as shown in **Fig 10.4.5**.

Sharpening the blade in this manner will give a cambered edge to the blade as shown in **Fig 10.4.6**.

Using the Plane Camber Jig to Sharpen a Straight Edge Blade

The jig can also be used to sharpen straight edge blades.

With the camber plate parallel to the base plate of the jig, secure it in place using the camber lock knobs as shown in **Fig 10.4.7**. The blade can then be sharpened to produce a straight edge.

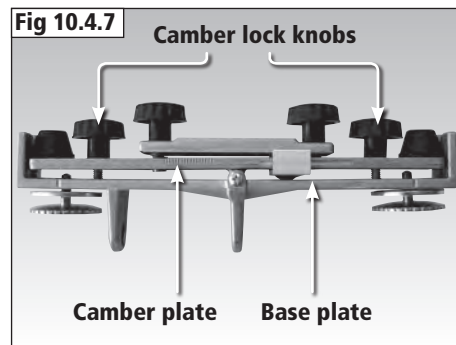
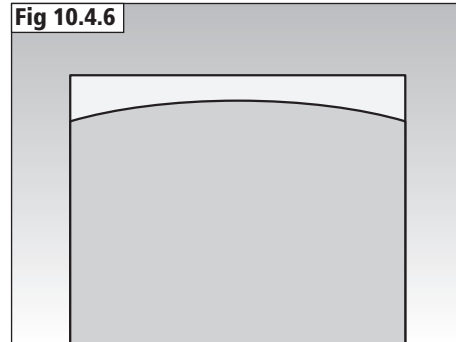
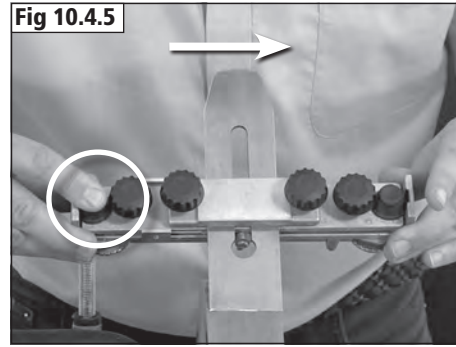

10.5. WG250/E Scissor Jig

Use to sharpen:

- Scissors
- Garden shears

The scissor jig mounts on to the support arm of the wet stone sharpener.

- A** Clamp
- B** Clamp knob
- C** Scissor holder
- D** Support plate
- E** Depth screw

Using the Scissor Jig

Adjust the depth screw to allow the scissor blade to be placed in the clamp as shown in **Fig 10.5.1** and tighten the depth screw and clamp knob.

Secure the scissor blade in the clamp as shown in **Fig 10.5.2** so the bevelled edge is facing the rear of the jig.

Mount the support arm in the upper position.

Slide the support plate onto the support arm as shown in **Fig 10.5.3** and secure in position at an angle that allows the bevelled edge of the blade to come into full contact with the stone as shown in **Fig 10.5.4**.

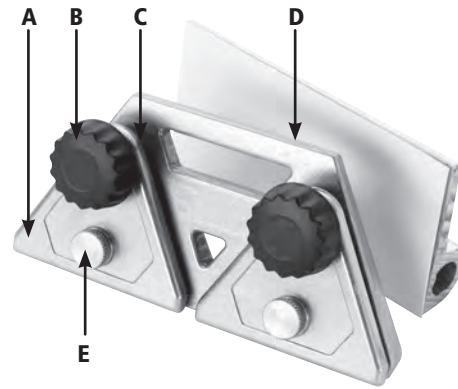

Fig 10.5.1

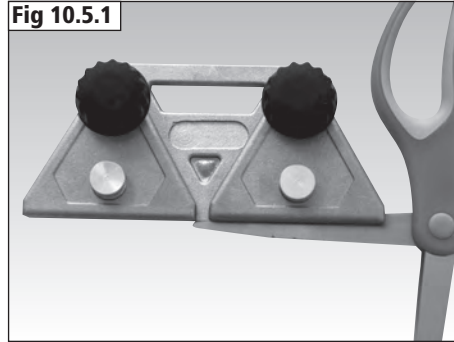

Fig 10.5.2

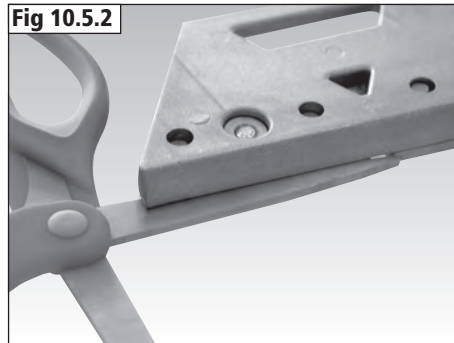

Fig 10.5.3

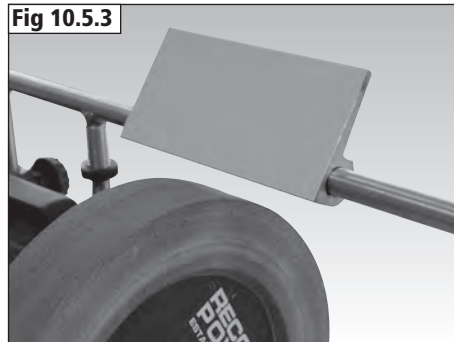
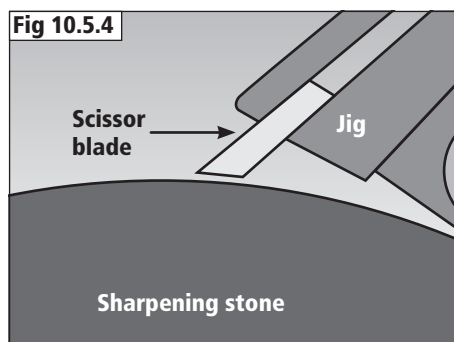

Fig 10.5.4



10.5. **WG250/E** Scissor Jig

Pass the blade across the stone to sharpen the bevelled edge, tilting the jig if necessary to follow the curve of the blade, **Fig 10.5.5**.

Carry out the above procedure for both blades of the scissors.

Both clamps may need to be used for holding longer blades such as garden shears.

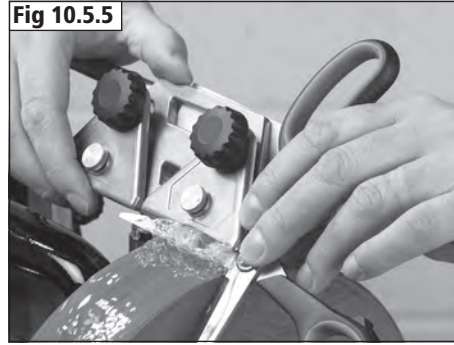

10.6. **WG250/F** Side Wheel Sharpening Jig

Use to sharpen cabinet scrapers

The side jig mounts on to the support arm of the wet stone sharpener and allows grinding against the side of the sharpening stone. It must be used in conjunction with the **WG250/I** Tool Rest Jig.

A Support arm

B Locking knob

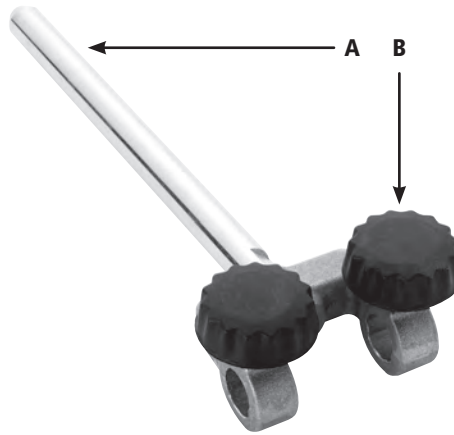

Using the Side Jig

Mount the support arm in the side position, attach the jig as shown in **Fig 10.6.1** and secure in place with the lock knobs.

Attach the **WG250/I** Tool Rest Jig as shown in **Fig 10.6.2** at 90° to the side of the stone and sharpen as shown.



10.7. WG250/G Short Knife Jig

Use to sharpen:

- Knives up to 100 mm (4") in length
- Pocket knives
- Small cutlery knives

- A** Clamp
- B** Depth screw
- C** Locking knob
- D** Stop
- E** Fine adjustment knob

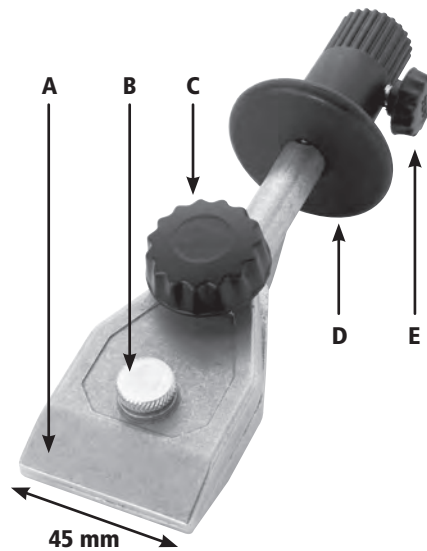

Using the Short Knife Jig

Place the support arm in the upper position.

Adjust the depth screw and locking knob to allow the blade to be held in the jig as shown in **Fig 10.7.1** and secure the blade in place, ensuring the cutting edge is as parallel to the clamp as possible.

Rest the stop of the jig on the support arm as shown in **Fig 10.7.2**.

Adjust the height of the support arm until the blade of the knife meets the stone at the required angle. The fine adjustment knob can be used to alter the position of the stop to achieve the most accurate angle possible.

Pass the blade across the stone to sharpen the bevelled edge, tilting the jig if necessary to follow the curve of the blade.

Fig 10.7.1



Fig 10.7.2



10.8. WG250/H Long Knife Jig

Use to sharpen:

- Knives over 100 mm (4") in length
- Large cutlery knives
- Draw knives

- A** Clamp
- B** Depth screw
- C** Locking knob
- D** Stop
- E** Fine adjustment knob

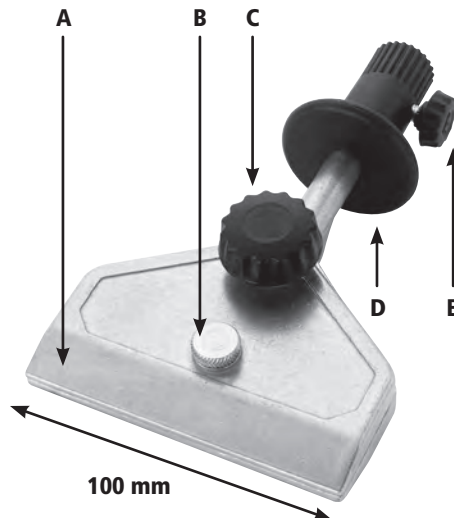

Using the Long Knife Jig

Place the support arm in the upper position.

Adjust the depth screw and locking knob to allow the blade to be held in the jig as shown in **Fig 10.8.1** and secure the blade in place, ensuring the cutting edge is as parallel to the clamp as possible.

Rest the stop of the jig on the support arm as shown in **Fig 10.8.2**.

Adjust the height of the support arm until the blade of the knife meets the stone at the required angle. The fine adjustment knob can be used to alter the position of the stop to achieve the most accurate angle possible.

Pass the blade across the stone to sharpen the bevelled edge, tilting the jig if necessary to follow the curve of the blade.

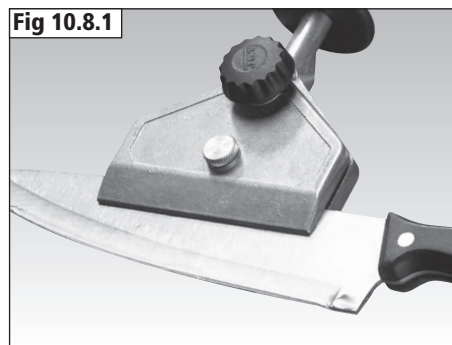

10.9. WG250/I Tool Rest Jig

Use to sharpen:

- Woodturning scraper chisels
- Screwdrivers
- Cabinet scrapers
- Hollowing tools
- Spoke shave blades

The tool rest jig mounts onto the support arm of the wet stone sharpener in either the upper or lower position.

A Lock knob

B Face

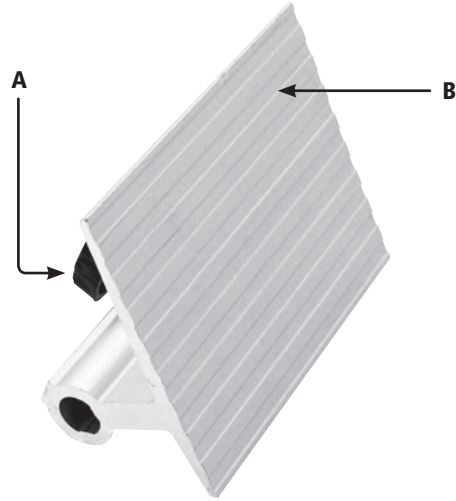

Using the Tool Rest Jig

Mount the support arm in the side position.

Slide the tool rest jig on to the support arm and fix in place with the lock knob as shown in **Fig 10.9.1**.

The required angle can be set using the position of the support arm and of the jig itself.

Rest the tool on the jig and apply to the sharpening stone as shown in **Fig 10.9.1**.



10.10. WG250/J Axe Jig

Use to sharpen:

- Carving axes
- Carpenter's axes

The axe jig slides onto the support arm of the wet stone sharpener.



Using the Axe Jig

Mount the support arm in the upper position and slide the axe jig onto it as shown in **Fig 10.10.1**.

Hold the axe head in the jig and tilt the axe blade slowly back and forth across the sharpening stone.

Turn the axe head over and repeat the process.



10.11. WG250/O Support Arm Extension Kit

The extension arm mounts on the support arm and allow the user to sharpen and hone without having to reposition the support arm and reset the angle of the jig.

- A** Lock knob
- B** Extension arm holder
- C** Extension arm

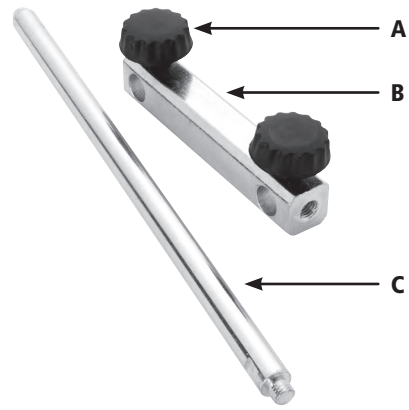

Using the Extension Arm

Place the extension arm holder onto the support arm ensuring the threaded hole is facing the opposite direction of the support arm and secure in place by tightening the lock knobs.

Mount the support arm in the side position.

Screw the extension arm into the holder as shown in **Fig 10.11.1**.

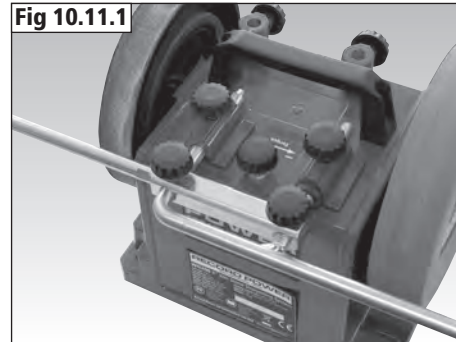

10.12. WG250/N Profiled Leather Honing Wheel

The profiled leather honing wheel is used to hone the insides of profiles on tool such as woodturning roughing gouges.

With the support arm mounted in the side position, apply the tool to the wheel as shown in **Fig 10.12.1**. Always hone with the wheel moving away from the blade to avoid damage to the leather.

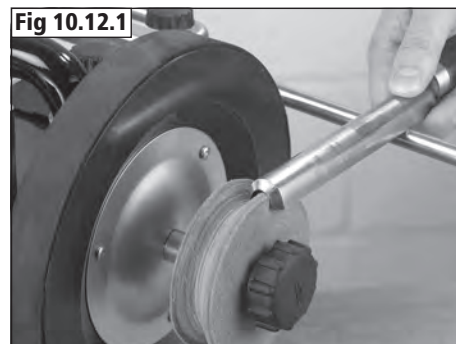

11. Maintenance

- Make all adjustments or machine maintenance with the machine unplugged from the power source.
- Repair and maintenance work on the electrical system must only be carried out by a qualified electrician.
- All protective and safety devices must be re-attached immediately after completion of cleaning, repair and maintenance work.
- Defective safety devices must be replaced immediately.

Cleaning

- Regularly change the water in the water trough.
- Regularly clean the machine housing with a soft cloth preferably after each use.
- Never use solvents such as petrol, alcohol, ammonia water, etc. as they may damage the plastic parts.

Inspecting the brushes

- Disconnect from power source before inspection.
- Inspect the motor brushes after 300 hours of use.
- If the brushes are worn to 6 mm replace them. Always replace the brushes in pairs.

Replacing the Sharpening Stone

When the sharpening stone has worn to a diameter of approximately 100 mm (4") it must be replaced.

Disconnect the WG200 from the power source.

Loosen the nut and remove the stone.



Please note: The lock nut has a left hand thread and must be turned clockwise to loosen.

Always use a genuine Record Power replacement stone.

Before mounting the wheel it must be checked for flaws and damage such as cracks or breaks.

Further information on stone safety and mounting can be found in the **HSE book HSG17 (Third edition, published 2000)**.

Install the new stone and ensure a washer is placed on either side of it as shown in **Fig 11.1** and re-fit the nut.

Replacing the Honing Wheel

Disconnect the WG200 from the power source.

Loosen the lock knob and remove the honing wheel as shown in **Fig 11.2**.

Fit the new wheel to the machine, ensuring the 3 pins on the inside are inserted into the holes on the drive wheel, **Fig 11.3**. Re-fit the lock knob.

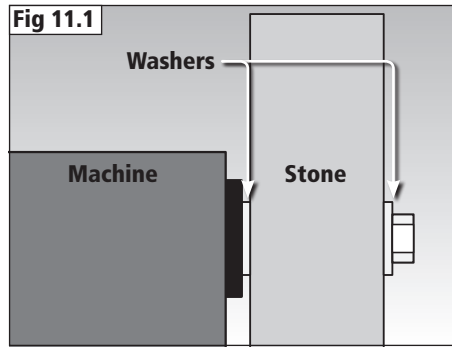

12. Troubleshooting

Problem	Possible cause	Suggested corrective action
Motor does not start.	<ol style="list-style-type: none">1. Power cable defective.2. Connections on the motor or switch defective.3. Carbon brushes worn.4. No power.	<ol style="list-style-type: none">1. Replace the power cable.2. Have the machine inspected by a qualified electrician.3. Replace the carbon brushes.4. Check power source and replace the fuse.
Machine vibrates excessively.	<ol style="list-style-type: none">1. Standing on an uneven surface.2. Abrasive wheel is unbalanced.	<ol style="list-style-type: none">1. Place the machine on a level, even surface.2. Use diamond trueing tool to make the wheel concentric to its shaft.
Sharpening surface is not flat.	<ol style="list-style-type: none">1. Worn Sharpening stone grit.2. Static grinding.	<ol style="list-style-type: none">1. Use stone grader or diamond trueing tool to correct the wheel's surface.2. Move the tool across the stone as you grind for even wear of the stone.
Sharpening surface is poor.	<ol style="list-style-type: none">1. Worn stone.2. Leather honing wheel is dry.3. Application pressure of tool is too high.	<ol style="list-style-type: none">1. Use stone grader to dress and refresh the stone's surface.2. Add honing compound to the wheel honing wheel.3. Use less force.
Brush sparks when switch is released.	<ol style="list-style-type: none">1. Carbon brushes are worn.2. Surfaces of the commutators are not clean.	<ol style="list-style-type: none">1. Replace the carbon brushes.2. Clean the surfaces of the commutators.

13. Electrical Connection and Wiring Diagram

Machines supplied for use in the UK are fitted with a 3 pin plug conforming to BS1363, fitted with a fuse conforming to BS1362 and appropriate to the current rating of the machine.

Machines supplied for use in other countries within the European Union are fitted with a 2 pin Schuko plug conforming to CEE 7/7.

Machines supplied for use in Australia and New Zealand are fitted with a 3 pin plug conforming to AS/NZS3112.

In all cases, if the original plug or connector has to be replaced for any reason, the wires within the mains power cable are colour coded as follows:

230 V (Single Phase)

Brown: Live (L)
 Blue: Neutral (N)
 Green and Yellow: Earth (E)

The wire coloured brown must always be connected to the terminal marked 'L' or coloured red.

The wire coloured blue must always be connected to the terminal marked 'N' or coloured black.

The wire coloured green and yellow must always be connected to the terminal marked 'E' or with the earth symbol or coloured green / green and yellow.



Earth Symbol



Double Insulated Symbol

It is important that the machine is effectively earthed. Some machines will be clearly marked with the double insulated logo. In this case there will not be an earth wire within the circuit.

In the case of the BS1363 plug for use in the UK, always ensure that it is

fitted with a fuse conforming to BS1362 appropriate to the rating of the machine. If replacing the original fuse, always fit a fuse of equivalent rating to the original. Never fit a fuse of a higher rating than the original. Never modify the fuse or fuse holder to accept fuses of a different type or size.

Where the current rating of the machine exceeds 13 A at 230 V, or if the machine is designated for use on a 400 V 3 phase supply a connector conforming to BS4343 (CEE17 / IEC60309) will be used. 230 V machines will be fitted with a blue 3 pin connector. The wiring for this type of this connector will be the same as shown above.

400 V, 3 phase machines will be fitted with a red 4 or 5 pin connector. The wiring for this type of connector is as shown below:

400 V (3 phase)

Brown: Live (L1)
 Black: Live (L2)
 Grey: Live (L3)
 Blue: Neutral (N)
 Green and Yellow: Earth (E)

The wire coloured brown must always be connected to the terminal marked 'L1'.

The wire coloured black must always be fitted to the terminal marked 'L2'.

The wire coloured grey must always be connected to the terminal marked 'L3'.

The wire coloured blue must always be connected to the terminal marked 'N' or coloured black.

The wire coloured green and yellow must always be connected to the terminal marked 'E' or with the earth symbol.

If in doubt about the connection of the electrical supply, always consult a qualified electrician.

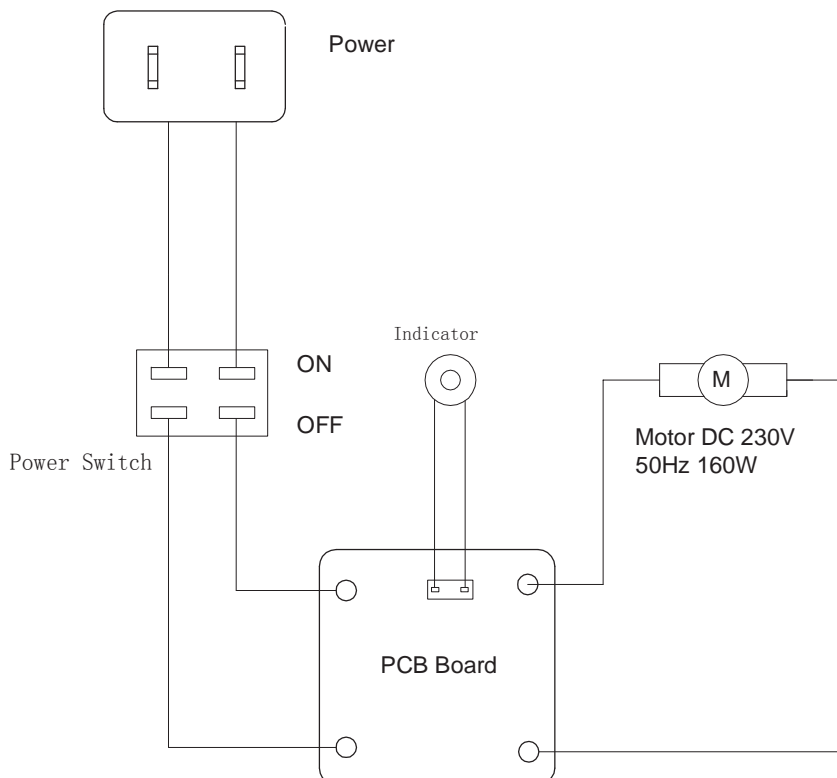

14. Parts Lists and Diagrams

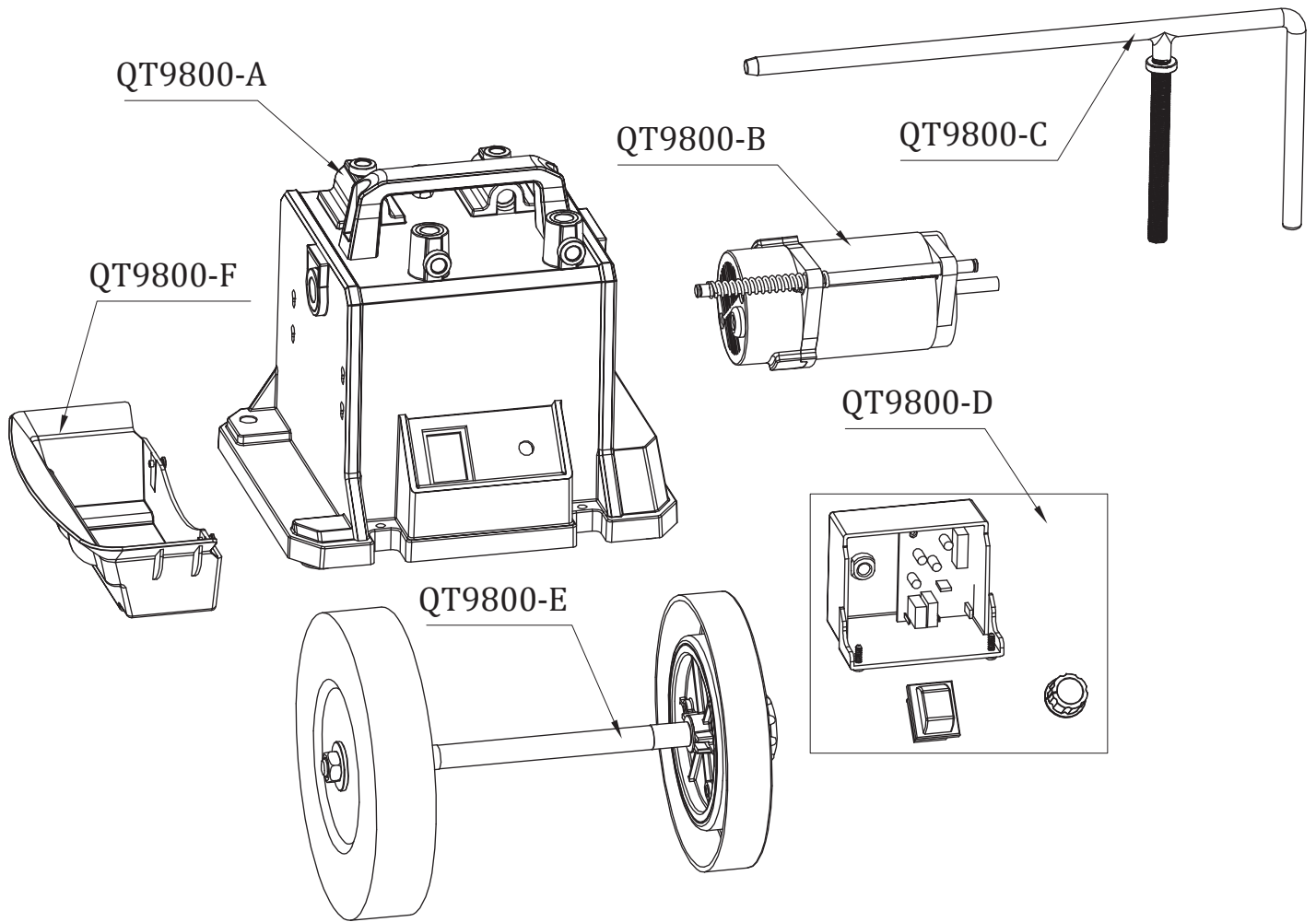

Part No.	Description	Quantity
QT9800-A	Machine body assembly	1
QT9800-B	Motor assembly	1
QT9800-C	Arm support assembly	1
QT9800-D	Switch box assembly	1
QT9800-E	Drive assembly	1
QT9800-F	Water tank assembly	1

14. Parts Lists and Diagrams

QT9800-A

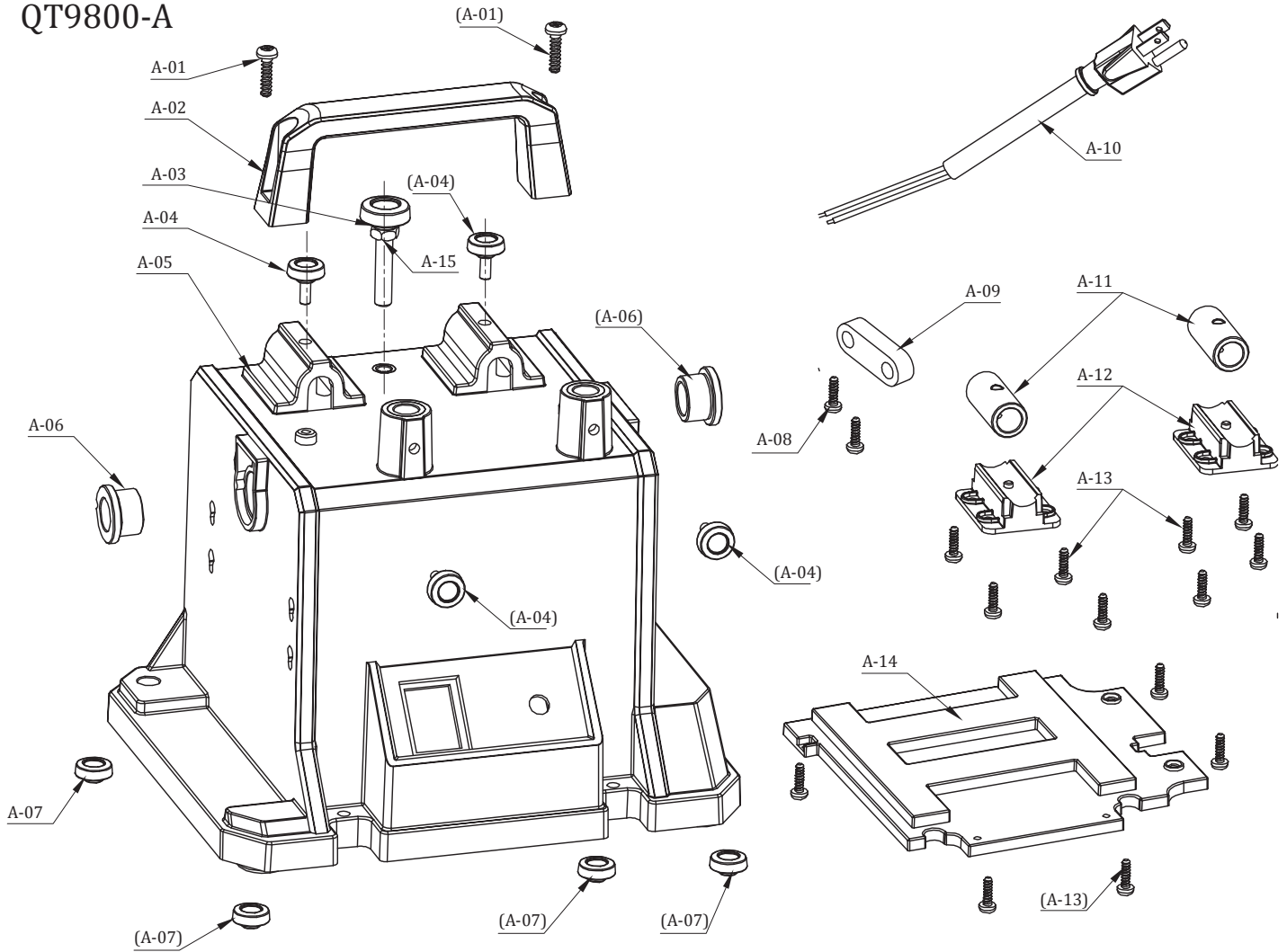

QT9800-A Machine Body Assembly

Part No.	Description	Quantity
A-01	Self-tapping screw ST5 x 20	2
A-02	Handle	1
A-03	Torque adjusting knob M8 x 35 mm	1
A-04	Lock knob M6 x 12mm	4
A-05	Machine body	1
A-06	Slide bearing	2
A-07	Rubber foot	4
A-08	Self-tapping screw ST4 x 14	2
A-09	Lock wire plate	1
A-10	Power cord	1
A-11	Tube 18 x 12.2 x 40 mm	2
A-12	Tube fixed bracket	2
A-13	Self-tapping screw ST4 x 12	1
A-14	Machine support plate	1
A-15	Set nut M8 x 35 mm	1

14. Parts Lists and Diagrams

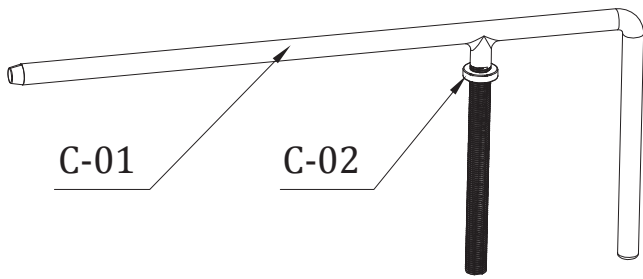

QT9800-C Support Arm Assembly

Part No.	Description	Quantity
C-01	Support arm	1
C-02	Micro adjustment nut	1

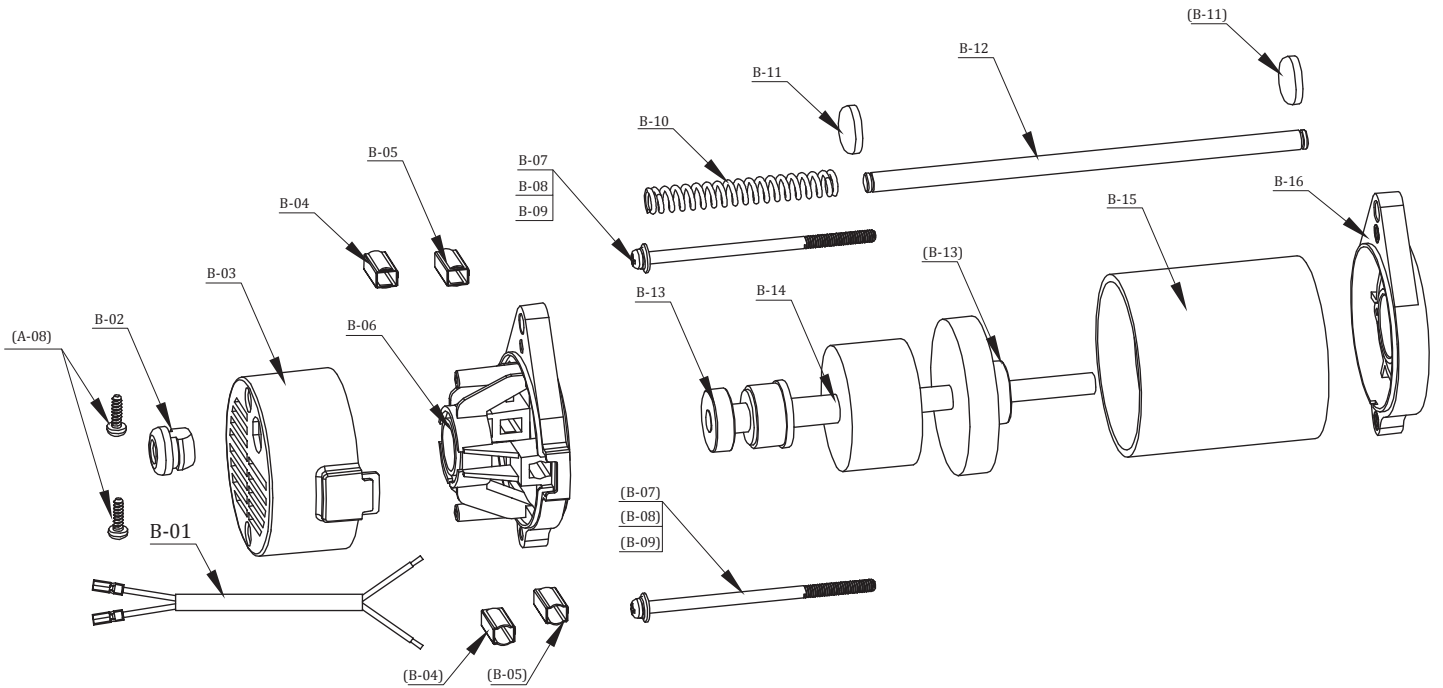

QT9800-B Motor Assembly

Part No.	Description	Quantity	Part No.	Description	Quantity
B-01	Connector wire 430 mm	1	B-09	Spring Washer Ø5	2
A-08	Self-tapping screw ST4 x 14	2	B-10	Spring Ø12 x 80 mm	1
B-02	Cable retainer	1	B-11	E-clip	2
B-03	Motor rear bracket	1	B-12	Motor shaft	1
B-04	Carbon brush	2	B-13	Bearing	2
B-05	Brush holder	2	B-14	Motor armature	1
B-06	Motor rear bracket cover	1	B-15	Armature field	1
B-07	Screw M5 x 100	2	B-15	Magnetic shoe	2
B-08	Flat Washer Ø5	2	B-16	Motor front bracket	1

14. Parts Lists and Diagrams

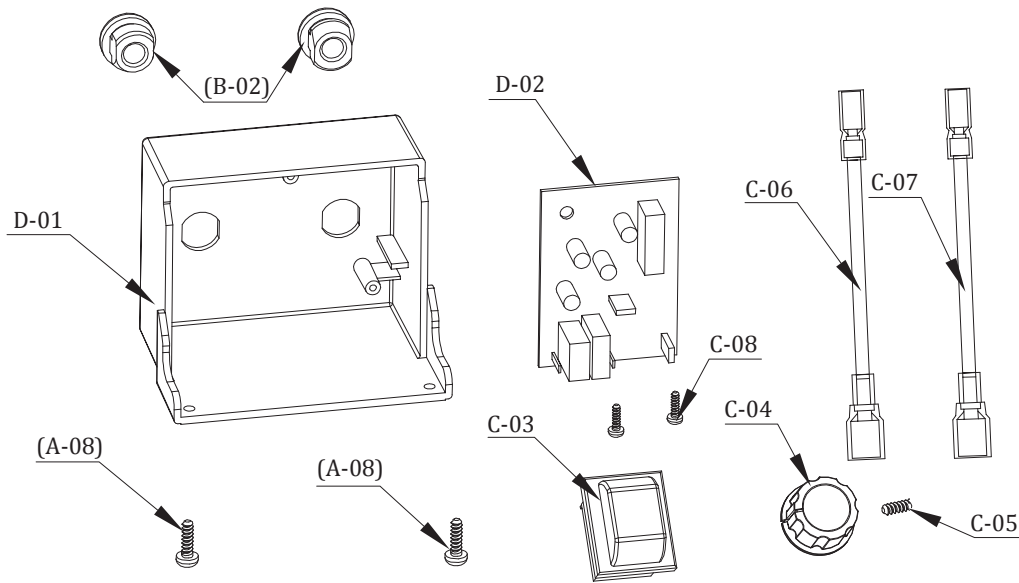

QT9800-D Power Switch Assembly

Part No.	Name Description	Quantity	Part No.	Name Description	Quantity
A-08	Self-tapping screw ST4 x 14	2	D-04	Power switch	1
B-02	Cable retainer	2	D-05	Indicator knob	1
D-01	Switch box	1	D-06	Set Screw M4 x 6D	1
D-02	PCB board	1	D-07	Brown wire 80 mm	1
D-03	Self-tapping screw ST3 x 12	2	D-08	Blue wire 80 mm	1

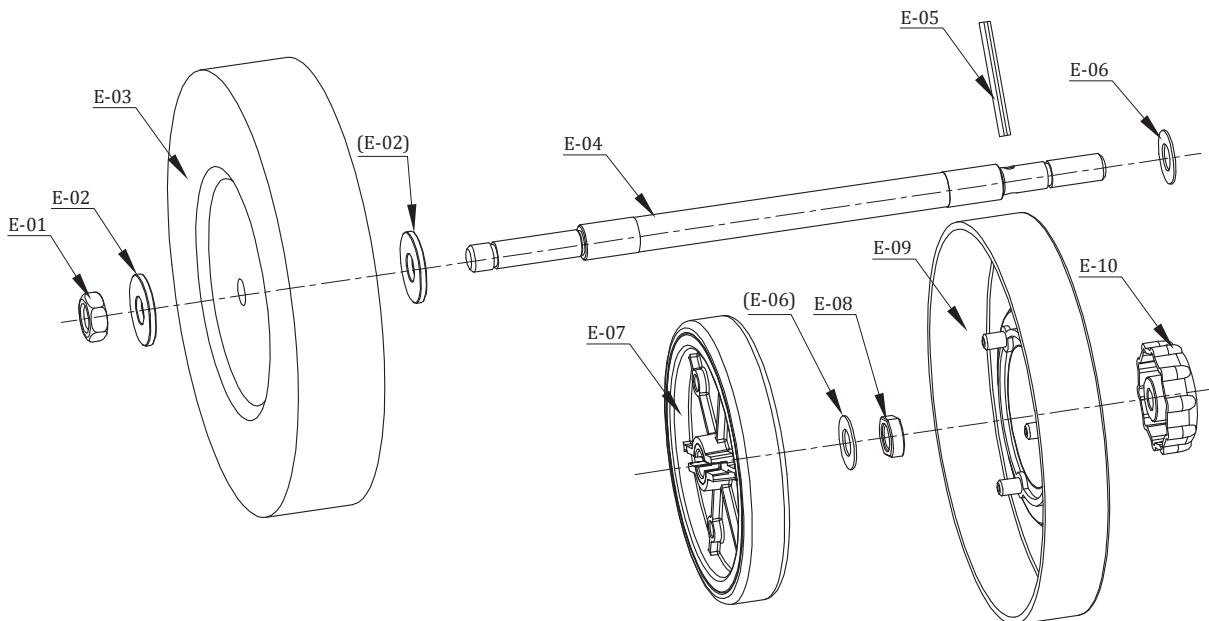

QT9800-E Drive Shaft Assembly

Part No.	Description	Quantity	Part No.	Description	Quantity
E-01	Left hand nut M12 x 1.75	1	E-06	Flat washer Ø12 x Ø24 x 1.5	2
E-02	Washer 3mm for stone	2	E-07	Drive wheel	1
E-03	Stone wheel	1	E-08	Lock nut	1
E-04	Main shaft	2	E-09	Honing wheel with Leather strip	1
E-05	Spring pin Ø4 x 40 mm	2	E-10	Honing wheel Lock knob M12	1

EU Declaration of Conformity

Cert No: EU / WG200 / 1

RECORD POWER LIMITED,

Centenary House, 11 Midland Way, Barlborough Links,
Chesterfield, Derbyshire S43 4XA

declares that the machinery described:-

1. Type: **Wet Stone Sharpener**

2. Model No: **WG200**

3. Serial No

Conforms with the following directives:-

Machinery Directive: 2006/42/EC
 EN61029-1:2009+A11
 EN ISO 12100:2010
 AfPS GS 2014:01



Issued by: TÜV Rheinland LGA Products GmbH, Tillystrasse 2 - 90431 Nürnberg

A handwritten signature in black ink, appearing to read 'Andrew Greensted', written over a dotted line.

Signed..... Dated: 01.09.2016

Andrew Greensted
Managing Director



RECORD POWER

ESTABLISHED 1909®

Woodworking Machinery and Accessories

Record Power Ltd, Centenary House, 11 Midland Way, Barlborough Links, Chesterfield, Derbyshire S43 4XA

Tel: +44 (0) 1246 571 020 Fax: +44 (0) 1246 571 030 www.recordpower.co.uk

To register a product and find your local stockist visit

recordpower.info

Made in China